

**Core**<sup>®</sup>  
by La Tavola



**la tavola**<sup>®</sup>

**Core**<sup>®</sup>  
by La Tavola

**Core**<sup>®</sup>  
by La Tavola

**la tavola**<sup>®</sup>

La Tavola's **Core**<sup>®</sup> Buffet Collection is the new buffet line  
designed by Sergio Sambonet.

# Design, Function, Identity.

La Tavola's products incorporate a keen awareness of ever-changing trends and design styles, whilst making sure to always deliver above operator's expectations in terms of functionality.

**Core**<sup>®</sup>  
by La Tavola



# Redefines Breakfast Buffet

The morning ritual becomes celebration of taste and elegance.

**Core**® transforms the breakfast buffet into a refined experience. Functional, versatile and designed to last, each piece combines practicality and style, setting a new standard in luxury hospitality.

**Core**®  
by La Tavola



# The Complete Dining Solution



Discover the **Core**® buffet, designed to showcase an international selection of dishes.

Equipped with hot and cold holding functions, it elegantly presents hot meals, fresh salads, appetizers, and desserts.

Ideal for modern restaurants, hotels, and catering, it combines functionality and design, delivering a complete and high-quality culinary experience.

**Core**®  
by La Tavola

## **At La Tavola, every material is chosen to elevate both design and performance.**

High-Pressure Laminate (HPL) offers strength and resilience with a contemporary edge, while powder-coated finishes bring sleek durability and vibrant character.

Solid surface adds seamless elegance and refined versatility. Alongside these, resin, gres, and PVD enrich the collection with texture, depth, and luminous detail. Together, they embody a philosophy of innovation and style – premium finishes that transform every presentation into an extraordinary experience.

**Core**<sup>®</sup>  
by La Tavola





A complete buffet, anywhere.



Core® brings the full buffet experience to even the smallest spaces. This mobile solution combines elegance and practicality, allowing hotels to create a refined presentation with everything in one compact, versatile cart. Designed to impress, built to adapt.

Core®  
by La Tavola



# Table of contents

<b>Market Displays</b>	16	<b>Warm-Holding, Cold-Holding, Cooking</b>	64
Market Boxes	20	<b>Warming Functions</b>	
Fresh Crates	24	Magic Chafer 2.0	66
Stands	28	Oyster Chafer	68
Market Elevation System	30	Chafing Dishes	69
Flower Pots	34	Warming Plate	70
Multi-Level Displays	34	Warming Tray	71
<b>Risers</b>	36	Goose Heat Lamp	72
Organic & Mineral Cross Risers	38	Carving Pro	74
HPL Cross Risers	40	Mini Chafer	75
Corner Risers	42	Induction Warming Top	76
High&Low Risers	44	Multi Point Induction Warming Plate	77
<b>Breakfast Essentials</b>	46	Ouzi Chafer	78
Display Trays	49	<b>Warming&amp;Cooling Functions</b>	
Room Service Trays	49	Hot&Cold Plate	79
Arcade Nesting Trays	50	<b>Cooling Functions</b>	
Free Form Displays	50	Cooling Tray	80
Lilypad Displays	53	Cooling Plate	81
Cake Stands	53	Bowl Holder	82
Cutting Boards	55	Chill-It Cooling System	82
Large Sliced Bread Containers	55	Oyster & Fruit de Mer Display	83
Cereal Container	57	Refrigerated Container	83
Superfood Container	57	<b>Cooking Functions</b>	
Slowdown Displays	58	Cooking Station	84
Pot & Butter Cooler	58	Wok Station	84
Juice Dispensers	61	Grill Teppanyaki Station	84
Alchemist	62	<b>Materials</b>	86
Hot Dispenser	62	HPL	87
Milk Dispenser	62	Powder Coated Finish	88
		MFC	89
		Titanium Coated Finish	90
		Solid Surface	91
		Grès	92
		Resin	93
		<b>Company Profile</b>	84

**Core**<sup>®</sup>  
by La Tavola

# Market displays

Enhancing buffet presentations with elegant multi-level setups.



# Build your ideal Market Display by combining modular elements

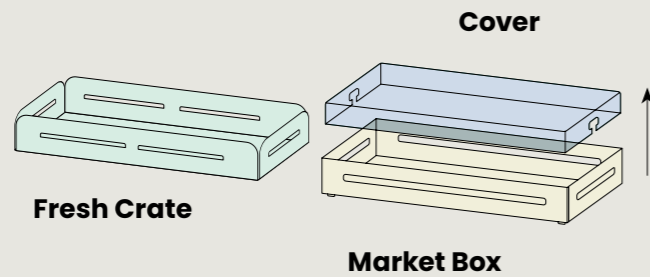

Mix and match **Boxes** (with or without boards and covers), **Fresh Crates** and **Stands** to create the setup you need.

Different heights and inclinations of the legs and stackable parts offer full flexibility-whether for visibility, protection, or quick access. Each piece adapts as your service evolves.

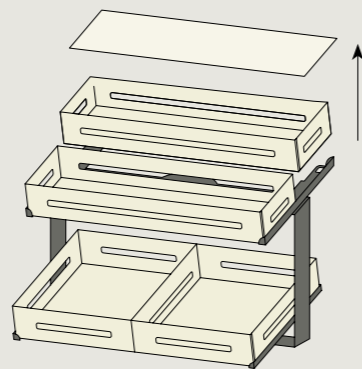
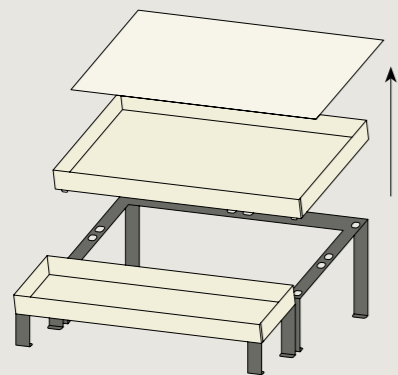
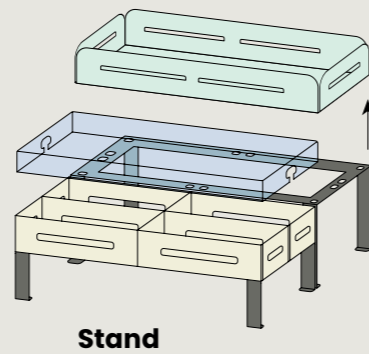

# And choose the colors and finishes that match your style

## Fresh Crates

Crafted from food-safe powder-coated steel, offered in 3 elegant color finishes.

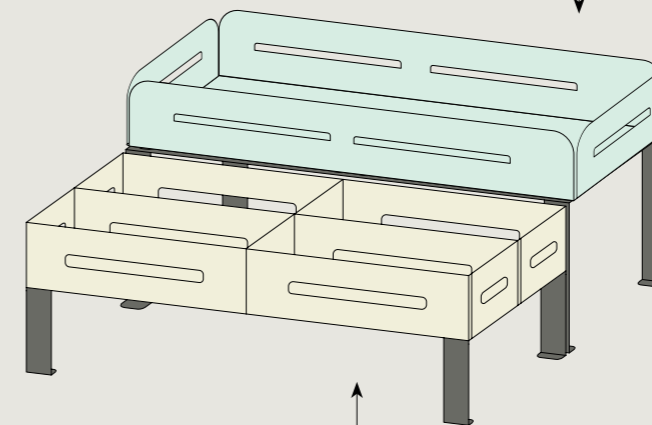

## Stands

Made of durable powder-coated structure available in 4 colours.

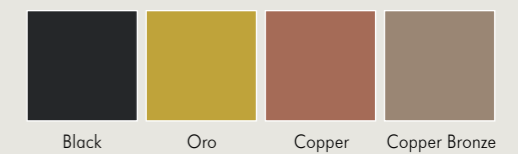

## Market Boxes

Made of HPL, a high-performance and hygienic material, available in 5 distinctive finishes.

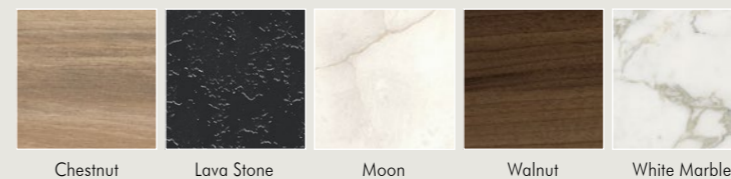



# Market Boxes

COMBINE THE ELEMENTS AND CREATE A UNIQUE MULTI-LEVEL SET-UP.

3 different heights, 4 colours of the stands and 5 HPL colours for the boxes with their PETG or HPL Covers. The main material used is HPL, a very durable, eco-friendly and hygienic material.

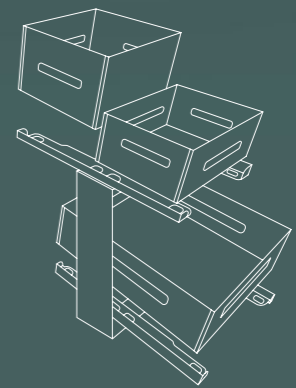

MARKET DISPLAYS

# Market Boxes



Market Box  
**LOW**  
L 53 W 32.5 H 5.5 cm  
1/1 GN



Market Box  
**LOW**  
L 32.5 W 26.5 H 5.5 cm  
1/2 GN



Market Box  
**LOW**  
L 53 W 16.3 H 5.5 cm  
2/4 GN



Market Box  
**LOW**  
L 26.5 W 16.3 H 5.5 cm  
1/4 GN



Market Box  
**MEDIUM**  
L 53 W 32.5 H 8.5 cm  
1/1 GN



Market Box  
**MEDIUM**  
L 32.5 W 26.5 H 8.5 cm  
1/2 GN



Market Box  
**MEDIUM**  
L 53 W 16.3 H 8.5 cm  
2/4 GN



Market Box  
**MEDIUM**  
L 26.5 W 16.3 H 8.5 cm  
1/4 GN



Market Box  
**TALL**  
L 53 W 32.5 H 11.5 cm  
1/1 GN



Market Box  
**TALL**  
L 32.5 W 26.5 H 11.5 cm  
1/2 GN



Market Box  
**TALL**  
L 53 W 16.3 H 11.5 cm  
2/4 GN



Market Box  
**TALL**  
L 26.5 W 16.3 H 11.5 cm  
1/4 GN

HPL FINISHES

- Chestnut
- Lava Stone
- Moon
- Walnut
- White Marble



Market  
**BOARD**  
L 53 W 32.5 H 1.5 cm  
Suitable for 1/1 GN



Market  
**BOARD**  
L 32.5 W 26.5 H 1.5 cm  
Suitable for 1/2 GN



Market  
**BOARD**  
L 53 W 16.3 H 1.5 cm  
Suitable for 2/4 GN



Market  
**BOARD**  
L 26.5 W 16.3 H 1.5 cm  
Suitable for 1/4 GN

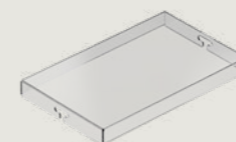

Transparent  
**PETG COVER**  
L 52 W 32.5 H 5 cm  
Suitable for:  
1x 1/1 GN  
2x 1/2 GN  
2x 2/4 GN  
4x 1/4 GN

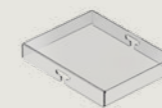

Transparent  
**PETG COVER**  
L 32.5 W 25 H 5 cm  
Suitable for:  
1x 1/2 GN  
2x 1/4 GN



Example of 4 Medium  
Market Boxes 1/4 GN with cover



# Fresh Crates

STYLISH, DURABLE, AND EFFORTLESSLY MODULAR, FRESH CRATE BRINGS STRUCTURE AND SOPHISTICATION TO EVERY SETTING.

- Black
- White
- Copper Bronze

**Fresh Crate** is a collection of elegant, **food-safe** painted metal crates designed to elevate buffet presentations. Available in three sizes, three refined colors, and finished **with a certified food-safe coating**, they feature different heights and internal dividers for maximum flexibility.

Combined with adaptable stands - offered in various heights, sizes, and inclinations - they enable dynamic, multi-level displays tailored for luxury hospitality.



MARKET DISPLAYS

# Fresh Crates



Fresh Crate  
**LOW**  
L 53 W 32.5 H 5 cm  
1/1 GN



Fresh Crate  
**LOW**  
L 32.5 W 26.5 H 5 cm  
1/2 GN



Fresh Crate  
**LOW**  
L 53 W 16.3 H 5 cm  
2/4 GN



Fresh Crate  
**LOW**  
L 26.5 W 16.3 H 5 cm  
1/4 GN



Fresh Crate  
**MEDIUM**  
L 53 W 32.5 H 7.5 cm  
1/1 GN



Fresh Crate  
**MEDIUM**  
L 32.5 W 26.5 H 7.5 cm  
1/2 GN



Fresh Crate  
**MEDIUM**  
L 53 W 16.3 H 7.5 cm  
2/4 GN



Fresh Crate  
**MEDIUM**  
L 26.5 W 16.3 H 7.5 cm  
1/4 GN



Fresh Crate  
**TALL**  
L 53 W 32.5 H 10.5 cm  
1/1 GN



Fresh Crate  
**TALL**  
L 32.5 W 26.5 H 10.5 cm  
1/2 GN



Fresh Crate  
**TALL**  
L 53 W 16.3 H 10.5 cm  
2/4 GN



Fresh Crate  
**TALL**  
L 26.5 W 16.3 H 10.5 cm  
1/4 GN



FOOD-SAFE PAINT FINISHES

- Black
- White
- Copper Bronze



## Fresh Crate with dividers

Fresh Crate 1/1 GN and 1/2 GN, Medium and Tall, are available also with 2 or 4 slots



MEDIUM 1/1 GN  
2 SLOTS



MEDIUM 1/1 GN  
4 SLOTS



MEDIUM 1/2 GN  
2 SLOTS



TALL 1/1 GN  
2 SLOTS



TALL 1/1 GN  
4 SLOTS



TALL 1/2 GN  
2 SLOTS



MARKET DISPLAYS  
**Stands**



Stand  
**LOW**  
L 53 W 33 H 10 cm  
1/1 GN



Stand  
**LOW**  
L 26.5 W 33 H 10 cm  
1/2 GN



Stand  
**LOW**  
L 53 W 16.5 H 10 cm  
2/4 GN



Stand  
**TILTED LOW**  
L 53 W 33 H 10.5 cm  
1/1 GN



Stand  
**TILTED LOW**  
L 26.5 W 33 H 10.5 cm  
1/2 GN



Stand  
**TILTED LOW**  
L 53 W 16.5 H 10.5 cm  
2/4 GN



Stand  
**TALL**  
L 53 W 33 H 18 cm  
1/1 GN



Stand  
**TALL**  
L 26.5 W 33 H 18 cm  
1/2 GN



Stand  
**TALL**  
L 53 W 16.5 H 18 cm  
2/4 GN



Stand  
**TILTED TALL**  
L 53 W 33 H 19 cm  
1/1 GN



Stand  
**TILTED TALL**  
L 26.5 W 33 H 19 cm  
1/2 GN



Stand  
**TILTED TALL**  
L 53 W 16.5 H 19 cm  
2/4 GN

POWDER-COATED FINISHES

- Black
- Oro
- Copper
- Copper Bronze

MARKET DISPLAYS  
**Multi-Level Stands**



Multi-Level Stand  
**2-LEVEL**  
L 55 W 39 H 26 cm  
1/1 GN



Multi-Level Stand  
**2-LEVEL**  
L 29 W 39 H 26 cm  
1/2 GN



Multi-Level Stand  
**TILTED 2-LEVEL**  
L 55 W 38 H 35 cm  
1/1 GN



Multi-Level Stand  
**TILTED 2-LEVEL**  
L 28.5 W 38 H 35 cm  
1/2 GN



Multi-Level Stand  
**3-LEVEL**  
L 55 W 39 H 50 cm  
1/1 GN



Multi-Level Stand  
**3-LEVEL**  
L 29 W 39 H 50 cm  
1/2 GN



Multi-Level Stand  
**TILTED 3-LEVEL**  
L 55 W 38 H 58 cm  
1/1 GN



Multi-Level Stand  
**TILTED 3-LEVEL**  
L 29 W 38 H 58 cm  
1/2 GN

POWDER-COATED FINISHES

- Black
- Oro
- Copper
- Copper Bronze



Space-saving and functional cart on wheels for HPL Market Boxes (1/1 GN, 1/2 GN, 2/4 GN, 1/4 GN), perfect for showcasing a wide variety of food in luxury buffet setups.



Multi-Level Display  
**VERTICAL BOXES  
DISPLAY CART**

L 60 W 52 H 140 cm  
1/1 GN

HPL BASE FINISHES

- Chestnut
- Walnut
- Lava Stone
- White Marble
- Moon



# Market Elevation System

4 DIFFERENT HEIGHTS, GLASS PIECES TO CREATE JUNCTIONS, AND HPL TOPS TO DISPLAY YOUR BUFFET SET-UP.

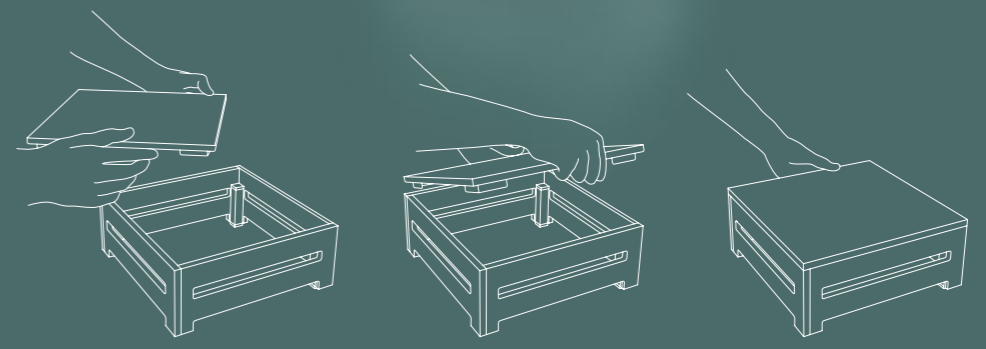

The Market Elevation System is a simple tool that allows for the creation of a functional and stunning buffet presentation

MARKET ELEVATION SYSTEM  
**Elevations**



MARKET ELEVATION SYSTEM  
**Crosses**

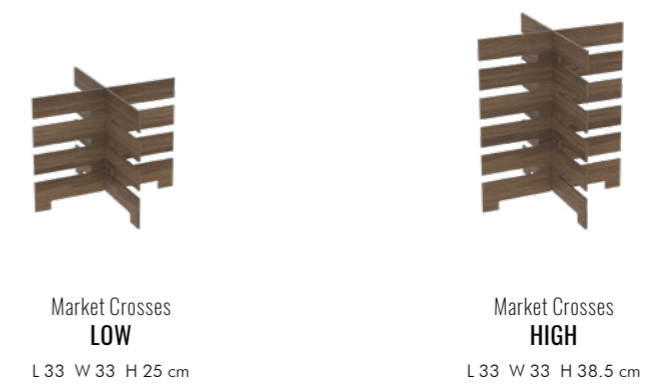

HPL FINISHES



HPL FINISHES

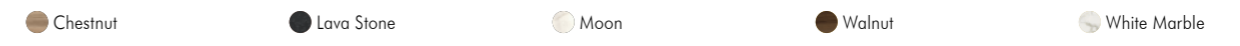

ELEVATIONS

**Tops**



HPL FINISHES

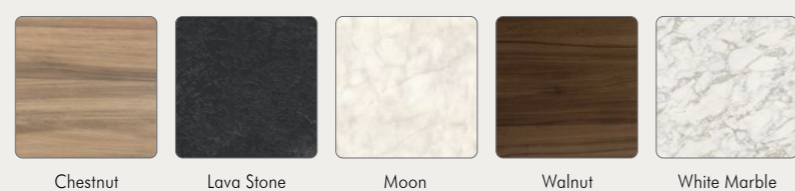

CROSSES

**Tops**



SOLID SURFACE FINISHES

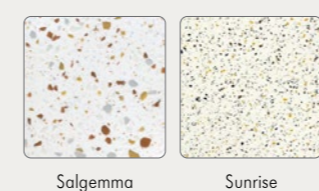

HPL FINISHES

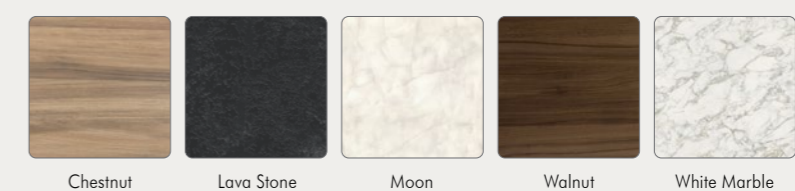

GLASS FINISH

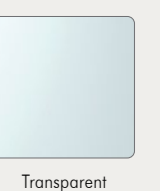

TRANSPARENT GLASS OR HPL CONJUNCTION ELEMENTS

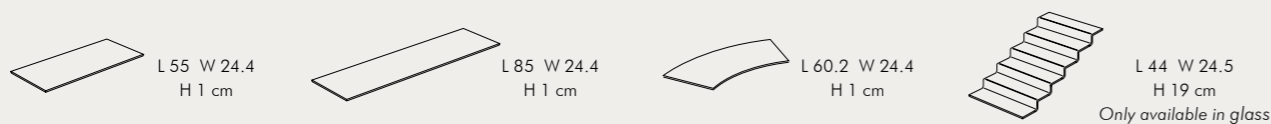

TRANSPARENT GLASS OR HPL CONJUNCTION ELEMENTS



MARKET DISPLAYS

## Flower Pots

- » EUTECTIC cooling technology - no ice or electricity required
- » Eutectic plate releases cold for up to 4 hours

- » Stainless steel 18/10 powder-coated finish base
- » HPL top



### FLOWER POTS

L 61 W 33.5 H 7 cm  
15 Bowls capacity

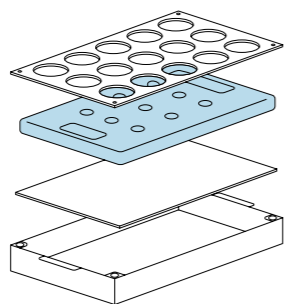

The hidden eutectic plate is placed in a stainless steel tray underneath the bowls.

### HPL FINISHES

- Chestnut
- Lava Stone
- Moon
- Walnut
- White Marble

Ceramic Mono Portion bowls  
Ø 11 H 6.5 cm 0.2 L



White



Black



MARKET DISPLAYS

## Multi-Level Displays

- » High Pressure Laminate tops with curved edges
- » Anti-slip protective feet
- » Powder-coated steel legs



### 2-LEVEL DISPLAY

L 58 W 38 H 47 cm



### 3-LEVEL DISPLAY

L 58 W 38 H 77 cm

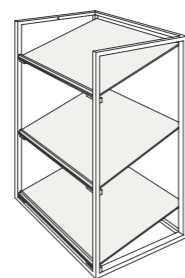

Each level can be easily reclined or removed according to the display requirements.

### POWDER-COATED FINISHES

- Black
- Oro
- Copper
- Copper Bronze

### HPL FINISHES

- Chestnut
- Lava Stone
- Moon
- Walnut
- White Marble



**Core**<sup>®</sup>  
by La Tavola

## Risers

Beautifully crafted elevations are the perfect choice for creating a dynamic presentation that will additionally boost the guests' appreciation of your buffet.

La Tavola offers a variety of options in terms of style, materials, heights and combinations.

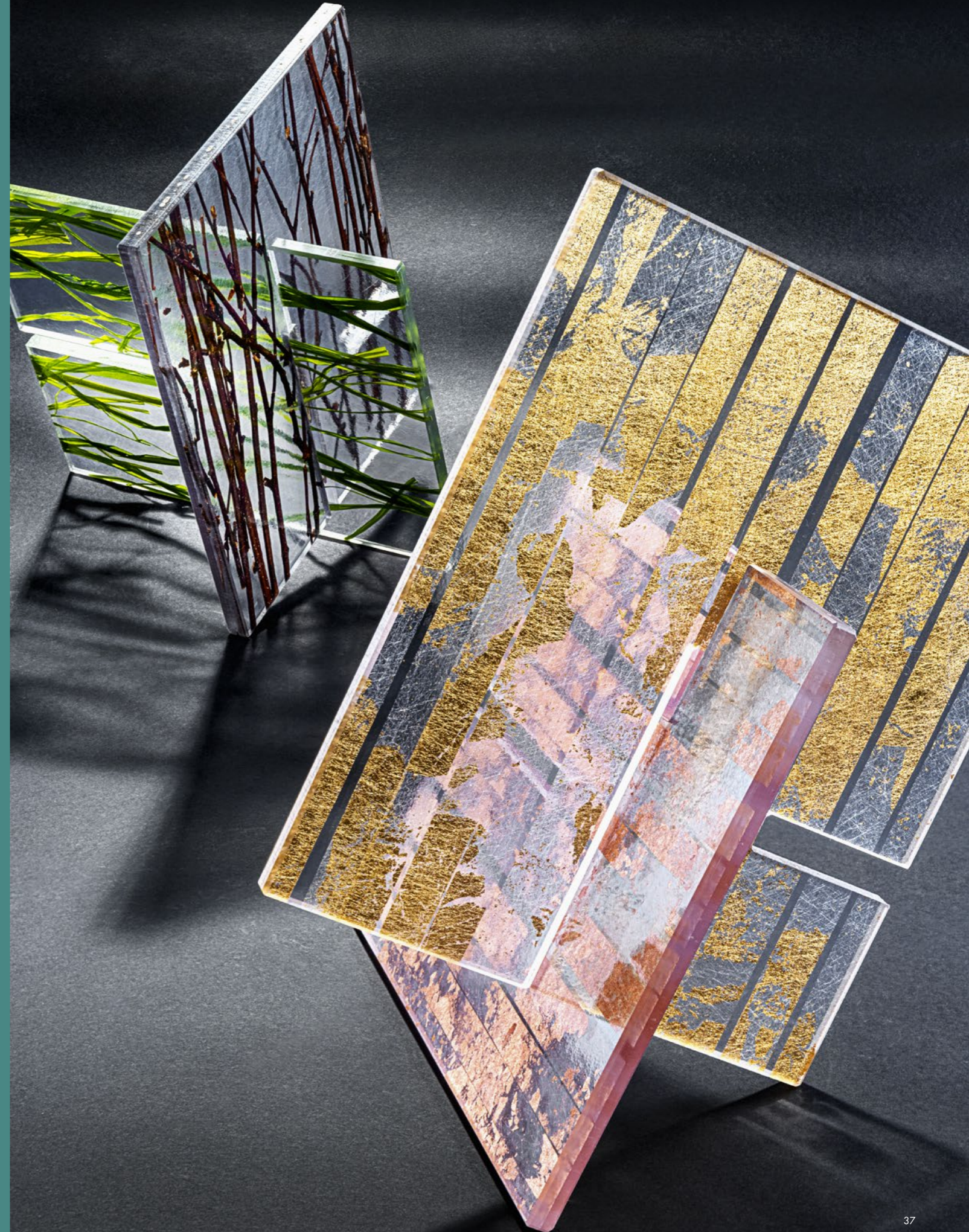

RISERS

# Organic & Mineral Cross Risers



Organic Cross Riser  
**GRASS TALL**  
L 19.5 W 19.5 H 31.5 cm



Organic Cross Riser  
**GRASS MULTI-LEVEL**  
L 33 W 26.5 H 10 cm



Organic Cross Riser  
**SPROUT TALL**  
L 19.5 W 19.5 H 31.5 cm



Organic Cross Riser  
**SPROUT MULTI-LEVEL**  
L 33 W 26.5 H 10 cm



Mineral Cross Riser  
**GOLD FLASH TALL**  
L 19.5 W 19.5 H 31.5 cm



Mineral Cross Riser  
**GOLD FLASH MULTI-LEVEL**  
L 33 W 26.5 H 10 cm



Mineral Cross Riser  
**COPPER FLASH TALL**  
L 19.5 W 19.5 H 31.5 cm



Mineral Cross Riser  
**COPPER FLASH MULTI-LEVEL**  
L 33 W 26.5 H 10 cm



Corner detail  
of HPL TOP



RISERS

## Tops



**SQUARE**  
38 x 38 cm



**ROUND**  
Ø 38 cm



**OBLONG**  
25 x 50 cm

SOLID SURFACE FINISHES

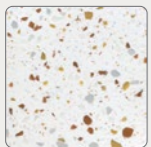

Salgamma



Sunrise

HPL FINISHES

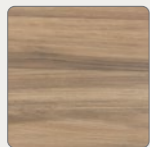

Chestnut



Lava Stone

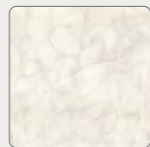

Moon

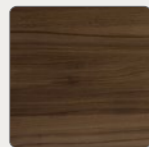

Walnut

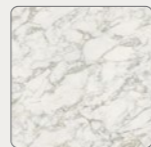

White Marble

GLASS

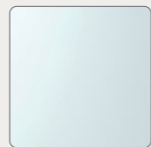

Transparent

RISERS

# HPL Cross Risers



HPL Cross Riser  
**TALL**  
L 19.5 W 19.5 H 31.5 cm



HPL Cross Riser  
**MULTI-LEVEL**  
L 33 W 26.5 H 10 cm

HPL FINISHES

- Chestnut
- Lava Stone
- Moon
- Walnut
- White Marble

RISERS

# Tops

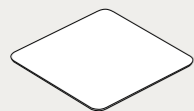

**SQUARE**  
38 x 38 cm



**ROUND**  
Ø 38 cm

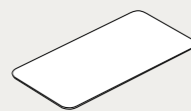

**OBLONG**  
25 x 50 cm

SOLID SURFACE FINISHES

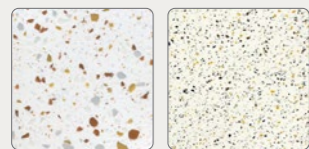

Salgemma Sunrise

HPL FINISHES

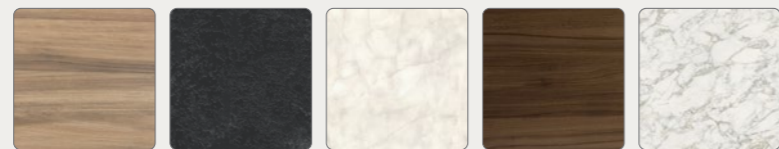

Chestnut Lava Stone Moon Walnut White Marble

GLASS

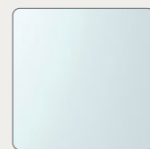

Transparent



Corner detail  
of HPL TOP

RISERS  
**Corner Risers**



Corner Riser  
**MINIMALIST LOW**  
L 15.5 W 15.5 H 18 cm



Corner Riser  
**MINIMALIST MEDIUM**  
L 15.5 W 15.5 H 23.5 cm



Corner Riser  
**MINIMALIST TALL**  
L 15.5 W 15.5 H 29 cm



Corner Riser  
**ORIENTAL LOW**  
L 15.5 W 15.5 H 18 cm



Corner Riser  
**ORIENTAL MEDIUM**  
L 15.5 W 15.5 H 23.5 cm



Corner Riser  
**ORIENTAL TALL**  
L 15.5 W 15.5 H 29 cm

POWDER-COATED FINISHES

- Black
- Oro
- Copper
- Copper Bronze

RISERS

**Tops**

- 

**SQUARE**  
38 x 38 cm
- 

**ROUND**  
Ø 38 cm
- 

**OBLONG**  
25 x 50 cm

SOLID SURFACE FINISHES

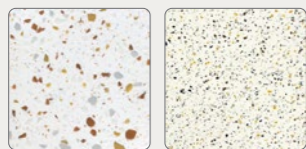

Salgemma Sunrise

HPL FINISHES

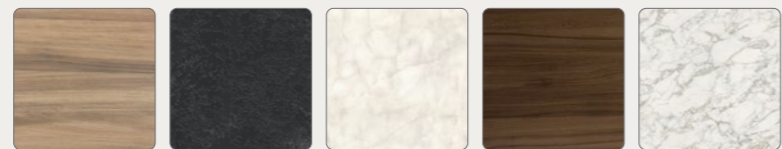

Chestnut Lava Stone Moon Walnut White Marble

GLASS

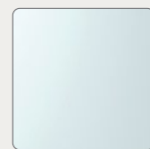

Transparent



Corner detail of  
SOLID SURFACE TOP

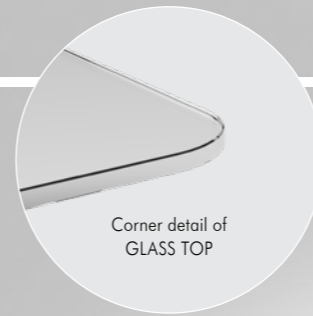

Corner detail of  
GLASS TOP



RISERS

# High&Low Risers

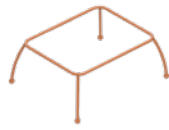

High&Low Riser  
**OBLONG LOW**  
L 27 W 33 H 13 cm



High&Low Riser  
**OBLONG MEDIUM**  
L 27 W 33 H 17 cm



High&Low Riser  
**OBLONG TALL**  
L 27 W 33 H 21 cm



Example of oblong with top



High&Low Riser  
**ROUND LOW**  
L 21 W 22 H 13 cm



High&Low Riser  
**ROUND MEDIUM**  
L 21 W 22 H 17 cm



High&Low Riser  
**ROUND TALL**  
L 21 W 22 H 21 cm



Example of Round with top



High&Low Riser  
**TILTED LOW\***  
L 30.5 W 30.5 H 21 cm



High&Low Riser  
**TILTED MEDIUM\***  
L 30.5 W 30.5 H 29 cm



High&Low Riser  
**TILTED TALL\***  
L 30.5 W 30.5 H 34 cm



Example of Tilted with bowl

POWDER-COATED FINISHES

- Black
- Oro
- Copper
- Copper Bronze

RISERS

## Tops



**ROUND**  
Ø 23 cm



**OBLONG**  
26.5 x 32.5 cm

SOLID SURFACE FINISHES

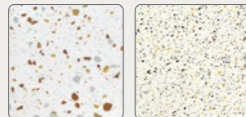

Salgemma Sunrise

HPL FINISHES

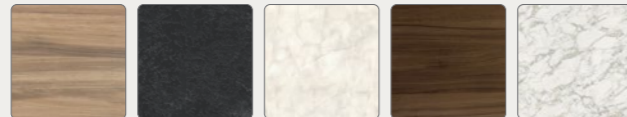

Chestnut Lava Stone Moon Walnut White Marble

PORCELAIN

## Bowls

\*Porcelain bowls are suitable only for Tilted High&Low



Ø 25 H 6.5 cm Cap. 1.7 L    Ø 25 H 9.5 cm Cap. 2.3 L



**Core**<sup>®</sup>  
by La Tavola

# Breakfast Essentials

Stylish essentials for a refined and memorable breakfast buffet.





## Display Trays

Ideal for sweet and savory delights, from breakfast to aperitivo

- » Futuristic and sleek shape
- » PETG cover
- » High pressure laminate with curved edges
- » Heavy-duty, small-size hinges
- » Powder-coated stainless steel details
- » Available in two heights



**DISPLAY TRAY  
LOW**

L 59 W 45 H 13.5 cm



**DISPLAY TRAY  
HIGH**

L 59 W 45 H 23.5 cm

### HPL FINISHES

- Chestnut
- Lava Stone
- Moon
- Walnut
- White Marble

### ST. ST. POWDER-COATED FINISHES

(Legs, handle and frames)

- Black
- Oro
- Copper
- Copper Bronze

## Room Service Trays

Ideal for room service

- » Feather-light, only 1.6 kg
- » Dishwasher safe
- » Shock-proof edges in injected polyurethane
- » 3 HPL finishes available with coordinated edge colour



**ROOM SERVICE TRAY**

L 60 W 40 H 5 cm



Stackable

### HPL FINISHES

- Noir Absolu
- Magma
- Walnut

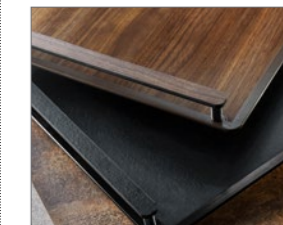

Cart for storage

## Arcade Nesting Trays

Ideal for an elegant display of petit fours, tartlets, and appetizers

- » Powder-coated steel sides
- » High Pressure Laminate or Solid Surface top
- » Available in three stackable sizes

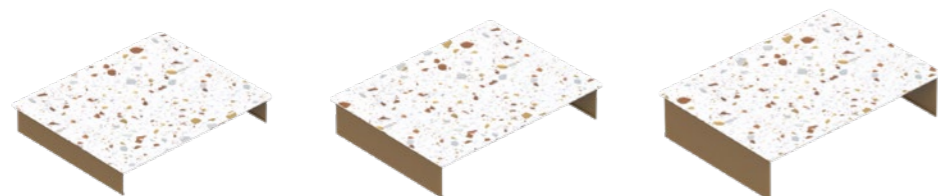

**ARCADE LOW**

L 40 W 32.5 H 6 cm

**ARCADE MEDIUM**

L 42.5 W 32.5 H 8 cm

**ARCADE TALL**

L 45 W 32.5 H 10 cm



Stackable trays for compact storage and impressive layered serving

### SOLID SURFACE FINISHES (Top)

- Salgamma
- Sunrise

### HPL FINISHES (Top)

- Chestnut
- Lava Stone
- Moon
- Walnut
- White Marble

### ST. ST. POWDER-COATED FINISHES (Legs)

- Black
- Oro
- Copper
- Copper Bronze



## Freeform Displays

Ideal for canapés, finger food and mini pastries

- » High Pressure Laminate tops with curved edges
- » Powder-coated steel legs
- » Anti-slip protective feet



**FREEFORM OVAL**

L 35 W 21.5 H 13 cm



**FREEFORM TRIANGLE TALL**

L 45 W 25 H 13 cm



**FREEFORM CURVY**

L 35 W 14.5 H 6 cm



**FREEFORM TRIANGLE LOW**

L 45 W 25 H 6 cm

### HPL FINISHES (Tops)

- Chestnut
- Lava Stone
- Moon
- Walnut
- White Marble

### ST. ST. POWDER-COATED FINISHES (Legs)

- Black
- Oro
- Copper
- Copper Bronze





## Lilypad Displays

Ideal for elegant presentation of breakfast items, brunch delicacies and tea-time

- » Powder-coated Stainless steel
- » Up to 4 elevation levels for buffet displays
- » Round HPL or Solid Surface tops bonded with structure



**LILYPAD DISPLAY  
2-LEVEL**  
Ø 24 H 21 cm



**LILYPAD DISPLAY  
3-LEVEL**  
Ø 24 H 33 cm



**LILYPAD DISPLAY  
4-LEVEL**  
Ø 30 H 36 cm

### SOLID SURFACE FINISHES (Round tops)

- Salgemma
- Sunrise

### HPL FINISHES (Round tops)

- Chestnut
- Lava Stone
- Moon
- Walnut
- White Marble

### ST. ST. POWDER-COATED FINISHES (Structure and frames)

- Black
- Oro
- Copper
- Copper Bronze

## Cake Stands

Ideal for cakes, cupcakes and pastries presentations

- » Powder-coated base
- » High Pressure Laminate or Solid Surface top
- » Centering groove for dome cover

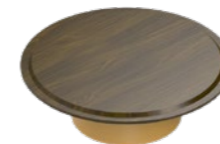

**CAKE STAND  
LOW**  
Ø 32 H 10 cm



**CAKE STAND  
TALL**  
Ø 32 H 19 cm



**POLYCARBONATE  
DOME COVER**  
Ø 30 H 18 cm

### SOLID SURFACE FINISHES (Round top)

- Salgemma
- Sunrise

### HPL FINISHES (Round top)

- Chestnut
- Lava Stone
- Moon
- Walnut
- White Marble

### ST. ST. POWDER-COATED FINISHES (Stand)

- Black
- Oro
- Copper
- Copper Bronze

## Cutting boards

Ideal for bread, meats and cheeses

- » Wooden cutting board
- » Durable and long-lasting



**BREAD CUTTING BOARD**  
with Oblong Tray  
L 53 W 32.5 H 2 cm  
1/1 GN



**BREAD CUTTING BOARD**  
with Oblong Tray  
L 36 W 30 H 2 cm  
1/2 GN



FOOD-SAFE PAINT FINISHES  
(Trays)

- Black
- White



Optional trays are made of stainless steel and powder-coated with food-contact grade paint



## Large Sliced Bread Containers

Ideal for sliced bread, pretzels, cookies, and small rolls

- » PETG Sliced bread container
- » HPL covers with hinged opening

- » Base in powder-coated stainless steel
- » Each container is available with or without partition



**LARGE SLICED BREAD CONTAINER**  
with single st. st base  
L 33 W 17.5 H 16 cm  
cap. 6.5 L  
cap. 6.2 L (with partition)



**LARGE SLICED BREAD CONTAINER**  
with 2-step st. st base  
L 33 W 17.5 H 25 cm  
cap. 6.5 L (each container)  
cap. 6.2 L (each container with partition)

HPL FINISHES  
(Cover)

- Chestnut
- Lava Stone
- Moon
- Walnut
- White Marble

ST. ST. POWDER-COATED FINISHES  
(Base)

- Black
- Oro
- Copper
- Copper Bronze

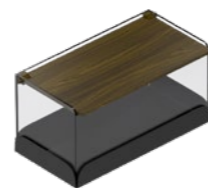



## Cereal Container

Ideal for all types of cereals

- » PETG cereal containers
- » HPL covers with hinged opening

- » Cut-out corner to hold service spoon



### CEREAL CONTAINER 3-STEP

with st. st base  
L 19 W 57 H 30.5 cm  
cap. 3.2 L (each container)

#### HPL FINISHES (Cover)

- Chestnut
- Lava Stone
- Moon
- Walnut
- White Marble

#### ST. ST. POWDER-COATED FINISHES (Base)

- Black
- Oro
- Copper
- Copper Bronze



## Superfood Container

Ideal for almonds, walnuts, cashews, pistachios, and varieties of dried fruit

- » PETG containers
- » HPL covers

- » The base is made of HPL and allows the containers to be centred and held in place
- » Waterproof and dishwasher-safe



### SUPERFOOD 4 CONTAINERS

with HPL base  
L 43 W 13 H 9 cm  
cap. 0.3 L (each container)

#### HPL FINISHES (cover and base)

- Chestnut
- Lava Stone
- Moon
- Walnut
- White Marble



## Slowdown Displays

Ideal for serving bread, breadsticks, jams, tea bags and napkins

- » Stainless steel base
- » Powder-coated with food-contact grade paint



**NAPKIN HOLDER**  
L 20 W 20 H 5 cm



**ITALIAN BREAD STICK HOLDER**  
L 23 W 12 H 4 cm



**OBLONG BREAD HOLDER**  
L 20 W 12 H 4 cm



**JAM POTS HOLDER**  
L 13.5 W 9 H 2.5 cm



**TEA / SUGAR BAGS HOLDER**  
L 6 W 5 H 3.5 cm

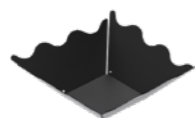

**FLOWER BASKET**  
L 26 W 26 H 11.5 cm



FOOD-SAFE PAINT FINISHES

- Black
- White
- Copper Bronze



## Pot & Butter Cooler

Ideal for yogurt cups, portion butter, jar desserts

- » Eutectic cooling technology - no ice or electricity required
- » Eutectic plate releases cold for up to 4 hours
- » Stainless steel base, powder-coated with food-contact grade paint

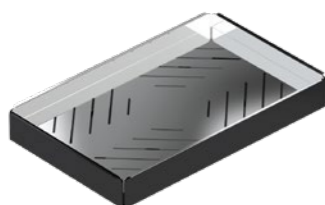

**POT COOLER**  
L 55 W 34 H 6.8 cm  
1/1 GN

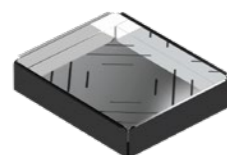

**POT COOLER**  
L 28.5 W 34 H 7 cm  
1/2 GN

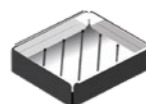

**BUTTER COOLER**  
L 21 W 18.5 H 5.5 cm



FOOD-SAFE PAINT FINISHES

- Black
- White
- Copper Bronze



Eutectic plate





## Juice Dispensers

Ideal for fruit juice and cold beverage

- » Food safe Anti-drip faucet
- » Crushed ice chilling insert

- » BPA free co-polyester liquid container (for juice)



**SINGLE  
JUICE DISPENSER**

L 20 W 35 H 46.5 cm  
cap. 6 L



**DOUBLE  
JUICE DISPENSER**

L 40 W 35 H 46.5 cm  
cap. 2x 6 L



**TRIPLE  
JUICE DISPENSER**

L 60 W 35 H 46.5 cm  
cap. 3x 6 L



**SYMPHONY  
JUICE DISPENSER**

L 20 W 33 H 46.5 cm  
cap. 6 L

HPL FINISHES  
(Cover)

- Chestnut
- Lava Stone
- Moon
- Walnut
- White Marble

ST. ST. POWDER-COATED  
FINISHES  
(Structure)

- Black
- Oro
- Copper
- Copper Bronze



Symphony  
Lava Stone & Black



Symphony  
White Marble & Oro



Symphony  
Moon & Copper Bronze

## Alchemist

Ideal for fruit juice and cold beverage

- » Powder-coated Stainless Steel
- » Holds and keeps cold 4 pitchers
- » Easily removable top to switch ice-packs
- » HPL top



### ALCHEMIST

L 40 W 27.5 H 9.5 cm  
Glass pitchers  
cap. 4x 1 L

#### HPL FINISHES (Top)

- Chestnut
- Lava Stone
- Moon
- Walnut
- White Marble



#### ST. ST. POWDER-COATED FINISHES (Structure)

- Black
- Oro
- Copper
- Copper Bronze

## Hot Dispenser

Ideal for hot beverages

- » Food safe anti-drip faucet
- » 220V electric heating available  
(not for hot milk and hot chocolate)
- » Stainless steel mirror finish



### INSULATED BEVERAGE DISPENSER

L 27 W 42 H 46 cm  
cap. 6 L  
⚡ 165 W

## Milk Dispenser

Ideal for chilled milk

- » Food safe anti-drip faucet
- » Crushed ice chilling insert
- » Mirror polished 18/10 st. st. liquid container  
for fresh milk



### CHILLED MILK DISPENSER

L 18 W 33 H 58.5 cm  
cap. 6 L

#### HPL FINISHES

- Chestnut
- Lava Stone
- Moon
- Walnut
- White Marble





# Warm-holding Cold-holding Cooking

Functional solutions for ever-changing needs.

One shared goal: to provide modern hoteliers with an accurate selection of adaptable, performing and qualitatively superior design solutions for their buffets.





## ■ Magic Chafer 2.0

The patented Humidity Control System® makes it ideal for serving any type of food

» FOR INDUCTION, GEL FUEL, ELECTRIC

» Stainless steel 18/10 cover and mechanical hinges

» Large glass window

» Cast aluminium water pan with patented Condensation Recovery System



HPL with anti sliding ring



St. St. with anti sliding ring



HPL Stand



St. St. Stand

### MAGIC CHAFER for induction

L 42 W 43 H 14 cm

2/3 GN

### MAGIC CHAFER W/ STAND electric or for fuel burner

L 42 W 43 H 17 cm

2/3 GN

700 W | gel fuel

Available with glass cover in 5 different luxury finishes.



Silverplated



Black



Venetian Gold

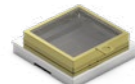

Gold



Platinum Champagne



### INDUCTION MAGIC CHAFER WITH STAND

The Magic Chafer with HPL stand is also available equipped with an integrated induction system delivered ready to operate.

Temperature range: 60 °C > 100 °C  
390 W



#### FOOD PANS



PORCELAIN  
2/3 GN  
1/3 GN



STAINLESS STEEL  
2/3 GN  
1/3 GN

#### STANDARD FINISHES

- Mirror Finish 18/10 st. st.
- Satin Finish 18/10 st. st.
- Silverplated

#### LUXURY FINISHES (Cover only)

- Black Titanium
- Venetian Gold Titanium
- Gold Titanium
- Platinum Champagne Titanium

#### HPL FINISHES

- Chestnut
- Lava Stone
- Moon
- Walnut
- White Marble



## ■ Oyster Chafer

Ideal for main dishes and starches

- » **FOR INDUCTION, GEL FUEL, ELECTRIC**
- » Stainless steel 18/10 and ferro-magnetic stainless steel
- » Opens to 100°
- » Stainless steel 18/10 mechanical hinge
- » Condensation recovery system
- » Cover with perforation to release excess steam
- » Food pans are available with or without partition
- » Easy to remove and replace during service
- » Can be used in dry/semi-dry mode

### STANDARD FINISH

- Mirror Finish 18/10 st. st.
- Silverplated

### LUXURY FINISHES (Cover only)

- Black Titanium
- Venetian Gold Titanium
- Gold Titanium
- Platinum Champagne Titanium



### ST. ST. POWDER-COATED FINISHES (Stand)

- Black
- Oro
- Copper
- Copper Bronze



**OYSTER CHAFER**  
for induction  
L 45.5 W 40 H 13.5 cm



**OYSTER CHAFER W/ STAND**  
electric or for fuel burner  
L 45.5 W 40 H 25.5 cm  
⚡ 400 W | 🔥 gel fuel

PORCELAIN  
FOOD PANS  
Ø 36 cm



1/1



1/1  
with partition

## ■ Chafing Dishes

Ideal for main dishes and starches

- » **FOR INDUCTION, GEL FUEL, ELECTRIC**
- » Stainless Steel 18/10
- » Hydraulic hinge
- » Large glass window
- » A stand is required when using in electric or gel fuel mode



**SQUARE CHAFER**  
for induction  
L 40 W 46.5 H 16 cm  
2/3 GN



**OBLONG CHAFER**  
for induction  
L 57.5 W 46.6 H 18 cm  
1/1 GN



**ROUND CHAFER**  
for induction  
L 44 W 53.5 H 16.5 cm



**ROUND SOUP STATION**  
for induction  
L 45 W 46.5 H 26.5 cm

FOOD PANS  
for Oblong and  
Square Chafer



FOOD PANS  
for Round Chafer



FOOD PAN  
for Soup Station



STAND  
for electric or gel fuel use



STANDARD FINISH  
● Mirror Finish 18/10 st. st.



## ■ Warming Plate

Ideal for any type of food

- » **ELECTRIC**
- » HPL external body
- » Stainless steel internal structure
- » Vitroceramic hardened top
- » Temperature range 50 > 95 °C
- » 3 Levels of temp control (50 > 70 > 95 °C)
- » Thermostat
- » Touch control
- » Power load 0,23 kW | 230 V | 50-60 Hz

### HPL FINISHES

- Chestnut
- Lava Stone
- Moon
- Walnut
- White Marble

Examples of induction compatible pan or container available



Ceramic Tajine



Cocottes



Porcelain Food Pans  
1/1 GN | 1/2 GN  
1/3 GN | 2/3 GN

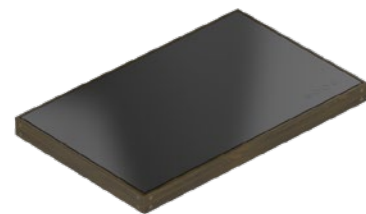

### WARMING PLATE

L 56 W 35.5 H 4.8 cm

1/1 GN

700 W

## ■ Warming Tray

Bread, pizza & focaccia, croissants and warm desserts

- » **ELECTRIC**
- » HPL support
- » St. st. round legs, powder-coated, with anti-slide
- » Stainless steel internal structure
- » PETG cover, reinforced with powder-coated st. st.
- » Vitroceramic hardened top
- » Temperature range 50 > 95 °C
- » 3 Levels of temp control (50 > 70 > 95 °C)
- » Thermostat
- » Touch control
- » Power load 0.23 kW | 230 V | 50-60 Hz

### HPL FINISHES (Support)

- Chestnut
- Lava Stone
- Moon
- Walnut
- White Marble

### ST. ST. POWDER-COATED FINISHES (Legs, handle and frames)

- Black
- Oro
- Copper
- Copper Bronze



### WARMING TRAY

L 59 W 45 H 23.5 cm

1/1 GN

700 W

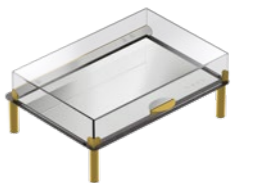

## Goose Heat Lamp

Heating lamp for Designer Carving Stations and Pizza & Focaccia Dishes



- » L 46 W 51 H 76 cm
- » Available in powder-coated and aluminium finishes
  - Black ● Oro ● Copper ● Copper Bronze
- » Available with 1 or 2 lights
- » Adjustable cap
- » Incorporated switch button
- » 250 W



### Stone tops



DESIGNER  
CARVING STATION  
L 54 W 33.5 H 5 cm  
1/1 GN

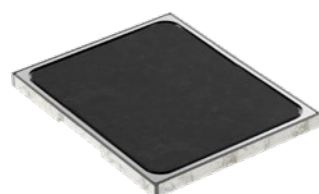

DESIGNER  
CARVING STATION  
L 54 W 66 H 8.5 cm  
2/1 GN

- » Premium Stone Carving Top
- » Not electric
- » Pan for juice recovery

The structure is made of HPL and available in the following finishes:

- Chestnut
- Walnut
- Lava Stone
- White Marble
- Moon

### Ceramic tops



SQUARE  
PIZZA & FOCACCIA DISH  
L 45 W 45 H 3 cm



ROUND  
PIZZA & FOCACCIA DISH  
Ø 50 H 3 cm

- » Feet made of solid rubber
- » Equipped with steel handles

The ceramic tops are available in the following finishes:

- Sahara Noir
- White Calacatta





## ■ Carving Pro

Presentation and carving of roasts and various grilled meats

- » **ELECTRIC**
- » Removable black granite top
- » Excess liquid collection system with recovery tank
- » Uniform temperature distribution
- » Easy access to temperature regulators
- » Maximum temperature up to 90° C (as measured on the granite top)

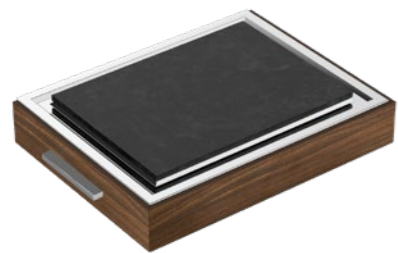

**CARVING STATION PRO**

L 74 W 53 H 13 cm

1/1 GN

2x 700 W



**GOOSE HEAT LAMP**

L 46 W 51 H 76 cm

250 W

ST.ST. FINISHES

- Mirror Finish 18/10 st. st.
- Satin Finish 18/10 st. st.

HPL FINISHES

- Chestnut
- Lava Stone
- Moon
- Walnut
- White Marble



Recovery tank



## ■ Mini Chafer

Ideal for sauces

- » Heat source: **GEL FUEL**



**MINI CHAFER**  
for fuel burner

L 22 W 21 H 11 cm

gel fuel



**DUAL MINI CHAFER**  
for fuel burner

L 49 W 29 H 11 cm

gel fuel



Cover holder

L 15 W 15 H 21 cm



Soup ladle holder

L 15 W 15 H 21 cm

ST.ST. FINISHES

- Mirror Finish 18/10 st. st.
- Satin Finish 18/10 st. st.

HPL FINISHES

- Chestnut
- Lava Stone
- Moon
- Walnut
- White Marble

**COCOTTES**  
Ø 18 cm





## ■ Induction Warming Top

Ideal for chafer and any induction compatible pan or container

- » **INDUCTION**
- » Temperature range: 104-203 °F / 40-95 °C
- » Temperature management with 12 levels of setting
- » Black Schott Ceran® glass

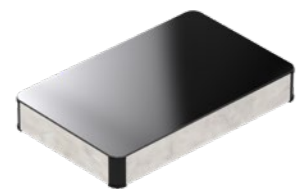

DUAL INDUCTION  
WARMING TOP

L 62 W 39 H 11 cm

600 W

1/1 GN



INDUCTION  
WARMING TOP

L 39 W 39 H 11 cm

300 W

2/3 GN

### HPL FINISHES

- Chestnut
- Lava Stone
- Moon
- Walnut
- White Marble

Examples of induction compatible pan or container available



Cocottes



Ceramic Tajine

## ■ Multi Point Induction Warming Plate

Ideal for chafer and any induction compatible pan or container

- » **INDUCTION**
- » Temperature range: 122-212 °F / 50-100 °C
- » Temperature displayed on digital display underneath Ceran® glass
- » "No pan no heat" technology for minimal energy wastage
- » Suitable for use with up to 4 induction-ready containers
- » Multi-point induction area 80 x 34 cm

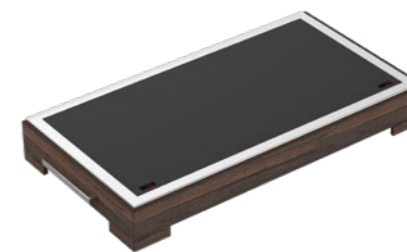

MULTI POINT INDUCTION  
WARMING PLATE

L 93.8 W 47.7 H 12.3 cm

1500 W

Examples of induction compatible pan or container available



Oyster Chafer



Cocottes



Ceramic Tajine

### ST.ST. FINISHES

- Mirror Finish 18/10 st. st.
- Satin Finish 18/10 st. st.

### HPL FINISHES

- Chestnut
- Lava Stone
- Moon
- Walnut
- White Marble



## ■ Ouzi Chafer

Presentation and carving of roasts and various grilled meats

- » **ELECTRIC, GEL FUEL**
- » Steam collection rim around the cover for condensation recovery
- » Microcast or polyethylene feet to prevent scratching of counter tops
- » The cover, food pans and water pans are removable for ease of operation and maintenance



### OUZI CHAFER

L 92 W 95 H 63 cm  
⚡ 700 W | 🔥 gel fuel

#### STANDARD FINISHES

- Mirror Finish 18/10 st. st.
- Satin Finish 18/10 st. st.
- Silverplated

#### ST. ST. FOOD PAN



Ø 70 cm

## ■ Hot&Cold Top

Ideal for cold and warm holding of finger food and plated dishes

- » **ELECTRIC**
- » Temperature range:
  - 90 °C / 194 °F
  - -5 °C / 23 °F
- » Digital temperature control and feedback
- » Stainless Steel structure with HPL panels
- » Removable cover (optional)

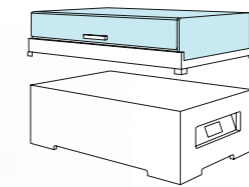

Removable cover is an optional additional component that can be easily placed and removed.

#### HPL FINISHES

- Chestnut
- Lava Stone
- Moon
- Walnut
- White Marble



### HOT&COLD TOP

L 57.2 W 37.2 H 20 cm  
1/1 GN  
⚡ 800 W

#### COCOTTES & TAJINE



Black



Cherry



Graphite Grey



Ceramic Tajine

#### PORCELAIN FOOD PANS



1/1 GN  
1/2 GN  
1/3 GN  
2/3 GN



## ■ Cooling Tray

Ideal for cold finger food, cold cuts, sushi

- » **EUTECTIC** cooling technology - no ice or electricity required
- » High Pressure Laminate with glass top
- » Ice Pack releases cold for up to 5 hours

- » Place the eutectic unit in a freezer at -18 °C (for 18 hours before use)
- » Transparent PETG cover reinforced with stainless steel frame



**COOLING TRAY**  
L 59 W 45 H 23.5 cm  
1/1 GN

### HPL FINISHES

- Chestnut
- Lava Stone
- Moon
- Walnut
- White Marble

### ST. ST. POWDER-COATED FINISHES (Legs, handle and frames)

- Black
- Oro
- Copper
- Copper Bronze

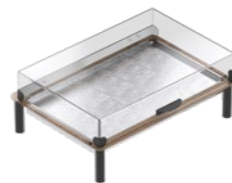

## ■ Cooling Plate

Ideal for cold finger food, cold cuts, sushi, fruit & salads, cold dips

- » **EUTECTIC** cooling technology - no ice or electricity required
- » High Pressure Laminate with glass top

- » Ice Pack releases cold for up to 5 hours
- » Place the Ice Pack in a freezer at -18 °C, for 18 hours before use

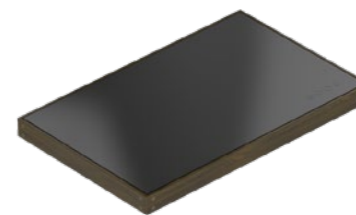

**COOLING PLATE**  
L 56 W 35.5 H 4.6 cm  
1/1 GN

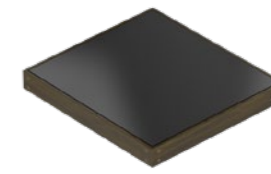

**COOLING PLATE**  
L 29.5 W 35.5 H 4.6 cm  
1/2 GN

### HPL FINISHES

- Chestnut
- Lava Stone
- Moon
- Walnut
- White Marble

## ■ Bowl Holder

Ideal for yogurt, muesli, fresh cheese, cold dips

- » **EUTECTIC** cooling technology - no ice or electricity required
- » Eutectic plate releases cold for up to 4 hours
- » Stainless steel 18/10 powder-coated finish base
- » Glass bowls with methacrylic cover and opening
- » HPL top
- » Methacrylic cover with hinge



**BOWL HOLDER**  
L 40 W 27.5 H 9.5 cm  
1/2 GN

### HPL FINISHES

- Chestnut
- Lava Stone
- Moon
- Walnut
- White Marble

### ST. ST. POWDER-COATED FINISHES

(Legs, handle and frames)

- Black
- Oro
- Copper
- Copper Bronze



**GLASS BOWL**  
w/ methacrylic cover with hinge  
Ø 23.5 cm (with cover)  
Ø 22.5 cm (without cover)

## ■ Oyster & Fruit de mer Display

Ideal for food-on-ice concept, oysters and raw seafood

- » HPL finish walls
- » Walls are also available in stainless steel "New Ice" 18/10
- » Polycarbonate ice container with st. st. drainer



Oyster & Fruit de mer  
**DISPLAY**  
L 64.5 W 53 H 23 cm  
2/1 GN

### ST. ST. FINISHES

- New Ice Finish 18/10 st. st.

### HPL FINISHES

- Chestnut
- Lava Stone
- Moon
- Walnut
- White Marble

## ■ Chill-it Cooling System

Ideal for ice-cream and sorbet

- » **EUTECTIC** cooling technology - no ice or electricity required
- » Stackable, double walled Chill-It pans containing food safe gel
- » Chill-It food pans release cold for up to 4 hours
- » Also available with transparent PETG cover reinforced with st.st. frame



**CHILL-IT COOLING SYSTEM**  
L 60 W 40 H 17 cm  
1/1 GN



**CHILL-IT COOLING SYSTEM WITH COVER**  
L 60 W 40 H 23 cm  
1/1 GN

### ST. ST. FINISHES

- Mirror Finish 18/10 st. st.
- Satin Finish 18/10 st. st.

### HPL FINISHES

- Chestnut
- Lava Stone
- Moon
- Walnut
- White Marble

**CHILL-IT PANS**  
1/3 GN and 1/2 GN  
(also available with transparent cover)



## ■ Refrigerated Containers

Ideal for salads and raw vegetables

- » **EUTECTIC** cooling technology - no ice or electricity required
- » Eutectic plate releases cold for up to 4 hours
- » HPL finish walls



**REFRIGERATED CONTAINER**  
Eutectic Set 3 pcs.  
L 59.6 W 36.6 H 10 cm  
1/1 GN



**REFRIGERATED CONTAINER**  
Eutectic Set 3 pcs.  
L 60 W 15 H 10 cm  
1/3 GN

### HPL FINISHES

- Chestnut
- Lava Stone
- Moon
- Walnut
- White Marble



**Stainless Steel Food Pans**  
1/3 GN | 1/1 GN | 1/9 GN  
H 6.5 cm



Available with cover

## ■ Cooking station

- » **INDUCTION POWERED**
- » Dual Cooking Station areas:  
Ø 14.5 cm ⚡ 1400 W  
Ø 21 cm ⚡ 2300 W  
All power ⚡ 3700 W can be directed on one large pan
- » Single Cooking Station area:  
Ø 21 cm ⚡ 2500 W
- » Automatic safety switch-off function
- » Booster function for quick heating
- » Timer function



**DUAL COOKING PLATE**  
L 62 W 49 H 13 cm  
⚡ 3700 W



**SINGLE COOKING PLATE**  
L 29 W 50 H 8 cm  
⚡ 2500 W



## ■ Wok station

- » **INDUCTION POWERED**
- » Cooking area: Ø 31 cm
- » Pan size: Ø 36 cm
- » Digital controls for regulation of temperature and other settings
- » Automatic safety switch-off function
- » Booster function for quick heating
- » Timer function



**WOK**  
L 49 W 62 H 20 cm  
⚡ 3700 W



## ■ Grill Teppanyaki station

- » **INDUCTION POWERED**
- » Cooking area: L 30 W 47 cm  
⚡ 3700 W (1400 W + 2300 W)
- » Booster function for quick heating
- » Timer function



**GRILL/TEPPANYAKI**  
L 62 W 49 H 13 cm  
⚡ 3700 W

### HPL FINISHES

- Chestnut
- Lava Stone
- Moon
- Walnut
- White Marble

Touch screen control panel with 9 power settings, safety lock and timer function. Activate commands with a simple touch and get feedback by control lights. Power levels (1-9) can be switched by sliding a finger on the "slider" or by pressing your finger directly on the chosen level.



# Materials

**SOLID SURFACE**

Used for riser tops, cake stands, and multi-level displays, solid surface provides a smooth, seamless appearance.

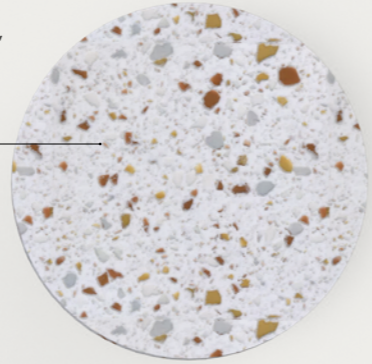

**MFC**

Warm tones and refined textures create a natural look that enhances any setting.



**HPL**

Elegant surfaces that blend timeless style with modern design freedom.



**POWDER COATED FINISH**

A sleek finish with endless possibilities, powder coating brings color, texture, and personality to every project.



**TITANIUM COATED FINISH**

This finish adds depth, brilliance, and a luxurious touch to every surface.



**RESIN**

Resin risers bring lightness and creativity to buffet displays.

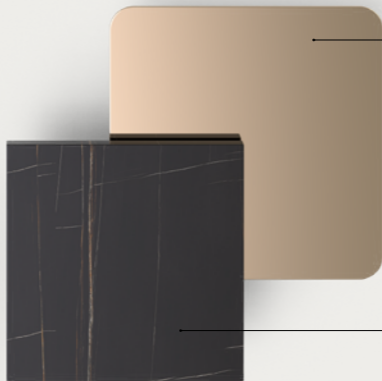

**GRÈS**

Grès surfaces combine elegance with versatility, they adapt seamlessly to different concepts and design styles.

# HPL

## Natural elegance, built to last

A refined surface that combines the look of natural materials with superior technical performance. HPL (High Pressure Laminate) is highly resistant to scratches, heat, and moisture, making it ideal for intensive, everyday use in hospitality settings. Easy to clean, durable, and available in a variety of elegant finishes, it ensures long-lasting beauty with minimal maintenance.

FINISHES

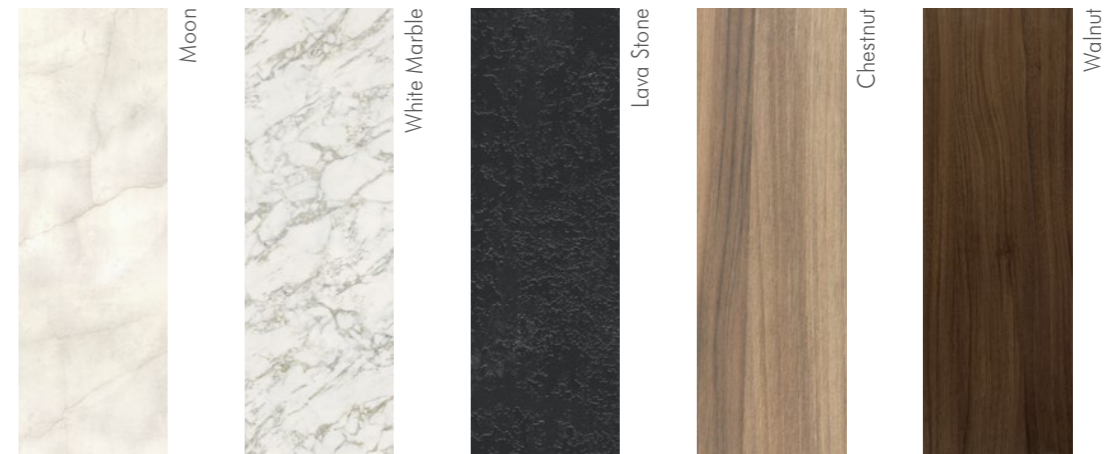

FEATURES



ITEMS

- » Action stations - Libro, Next, Symphony;
- » Buffet tables - Lite Nesting, Foldable Buffet tables, Foldable Cocktails tables;
- » Buffet essentials - juice dispensers, risers, trays, displays;
- » Mixology - Symphony front & back bar, Foldable front & back bar, Dynamic front bar;
- » Vertical display - Lite back bar, The Tower, The Egg, The Tree;
- » Carts - Coffee Break cart, Swift F&B line, Green Egg cart, Ouzi cart, Coffee Cabinet

# Powder Coated Finish

## High resistance, low maintenance

A refined finish that combines aesthetics with high performance. Powder coating is an advanced painting process in which dry pigment is electrostatically applied and cured at high temperatures, creating a strong, uniform, and long-lasting surface. Unlike traditional paint, powder coating resists scratches, moisture, corrosion, and UV exposure, making it the ideal choice for buffet structures and tables subject to intensive daily use. Its smooth, non-porous surface ensures easy cleaning and impeccable hygiene, while a wide range of finishes and textures offers maximum design flexibility.

### FINISHES



### FEATURES



UV-RESISTANT



EASY-TO-CLEAN



SUSTAINABLE MATERIAL



IMPACT-RESISTANT



DURABLE MATERIAL



CORROSION-RESISTANT



SCRATCH-RESISTANT

### ITEMS

- » Action stations - Libro, Next, Symphony;
- » Buffet tables - Lite Nesting, Foldable Buffet tables, Foldable Cocktails tables;
- » Buffet essentials - juice dispensers, risers, trays, displays;
- » Mixology - Symphony front & back bar, Foldable front & back bar, Dynamic front bar;
- » Vertical display - Lite back bar, The Tower, The Egg, The Tree;
- » Carts - Coffee Break cart, Swift F&B line, Green Egg cart, Ouzi cart, Coffee Cabinet

# MFC

## Timeless strength

Melamine Faced Chipboard (MFC) is a high-performance material. Its durable melamine surface provides excellent resistance to scratches, moisture, and daily wear, ensuring a long-lasting and attractive appearance even in high-traffic hotel and restaurant environments. The non-porous surface is easy to clean and maintain, supporting high hygiene standards essential in food service areas. MFC panels are available in a wide range of colors, textures, and finishes, allowing for versatile design solutions that match any décor or concept.

### FINISHES



### FEATURES



IMPACT-RESISTANT



SCRATCH-RESISTANT



FOOD-GRADE



UV-RESISTANT



HEAT-RESISTANT



SOLVENT-RESISTANT



ANTIBACTERIAL



SUSTAINABLE MATERIAL



EASY-TO-CLEAN

### ITEMS

- » Conference Table;
- » Meeting Table;
- » Lite Convivium;
- » Banqueting Tables

# Titanium Coated Finish

Luxury that lasts

A titanium-coated finish is created through PVD (Physical Vapor Deposition): a thin metallic film is applied to high quality stainless steel in vacuum, producing a surface that is exceptionally durable, hypoallergenic, and beautifully metallic in appearance. This treatment combines aesthetic refinement with high resistance to wear, corrosion, and abrasion – making it ideal for luxury cutlery used in demanding hospitality contexts.

## FINISHES



## FEATURES



## ITEMS

- » Flatware;
- » Magic Chafer Cover;
- » Oyster Chafer Cover;
- » Ouzi Chafer Cover

# Solid Surface

Shape hospitality with solid surface solutions

Solid surface materials are an excellent choice for the hospitality, restaurant, and catering industry, combining durability, hygiene, and aesthetics in a single solution. Their seamless and non-porous structure ensures that countertops remain hygienic and easy to maintain. Solid surface guarantees a continuous, elegant look that aligns with the high standards of the HoReCa industry.

## FINISHES

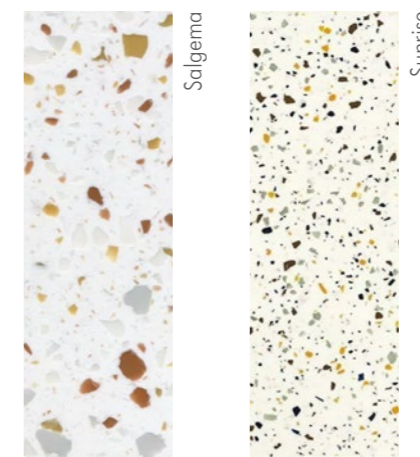

## FEATURES

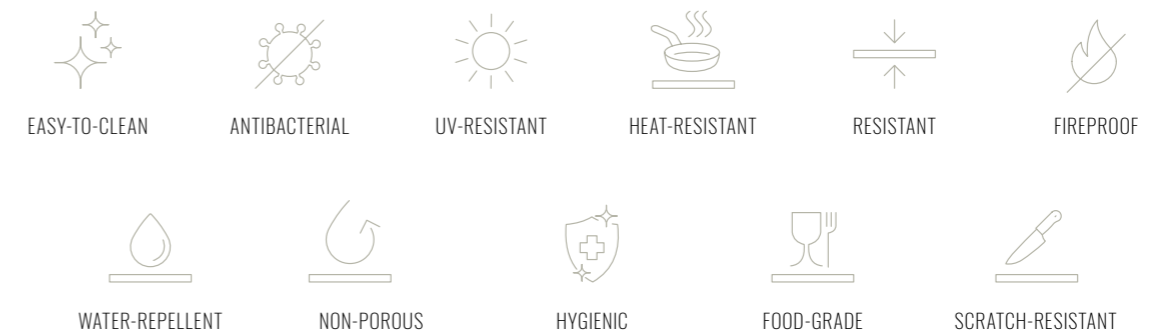

## ITEMS

- » Risers Tops;
- » Breakfast Essentials: Arcade Nesting Trays, Lilypad Displays, Cake Stand

# Grès

## A surface that inspires

Porcelain stoneware is the ideal material for buffet tables in the hospitality and catering sector, combining durability, hygiene, and style. Its dense, non-porous surface resists scratches, stains, and heat, ensuring long-lasting performance even under intensive daily use. Easy to clean and maintain, it guarantees impeccable hygiene in food service environments. Porcelain stoneware allows for the creation of elegant and versatile buffet solutions that meet both functional and aesthetic needs.

### FINISHES

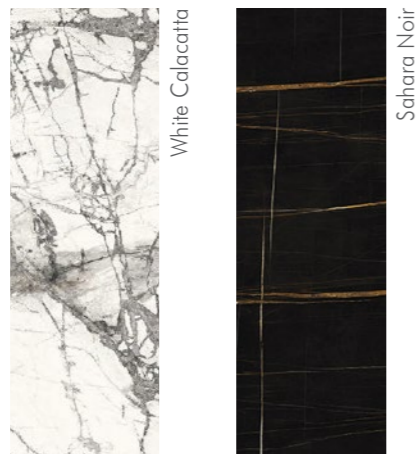

### FEATURES



### ITEMS

- » Pizza & Focaccia Dishes;
- » Icona Secret

# Resin

## Eco-friendly elegance for modern buffets

La Tavola's Organic and Mineral Risers have the added benefit of being made from a specially formulated co-polyester resin that combines performance with environmental responsibility. Eco-resin incorporates 40% pre-consumer recycled content without compromising aesthetics or overall physical properties, is compatible with one of the largest post-consumer recycling streams, and is GREENGUARD® Indoor Air Quality and BREEAM Certified.

### FINISHES



### FEATURES



### ITEMS

- » Organic & Mineral Cross Risers

LA TAVOLA IS A PERFECT REPRESENTATIVE OF THE NUMEROUS MEDIUM SIZED COMPANIES THAT FUEL ITALY'S ECONOMY: LA TAVOLA IS OWNED AND MANAGED BY THE SAMBONET FAMILY, WHOSE MEMBERS HAVE SUPPLIED AND SERVED THE HOSPITALITY INDUSTRY FOR GENERATIONS.



# A Family Affair

7 Generations at the service of the hospitality industry.



## 1831

The beginnings. Giuseppe Sambonet opens up a workshop to produce and sell silver handmade crafts.



## 1919

Giulio Sambonet grows the shop into a factory. The factory location is in Vercelli, in the same building where the La Tavalas showroom is currently located.



## 1946

Giorgio leads the company's expansion to the foreign market. Later in his life he will focus on his career as a painter and writer, his work is currently showcased in 3 different museums in Vercelli, Italy.

## 1974

Giulio and Sergio Sambonet concentrate their effort in serving the hospitality industry.

They manage the Sambonet company until 1986, year in which they sell their shares to start new companies: Table Top Engineering & Design, Sant'Andrea (in partnership with Oneida) and La Tavola®.



## 2011

Matteo joins the team, the 7<sup>th</sup> generation of the Sambonet family to nurture a passion for the hospitality industry.

The brand new buffet action stations Wonderbuffet® line is created.



## 2025

Sergio and Matteo Sambonet joined forces to conceive, design, and launch the new Core® buffet line, combining heritage, innovation, and Italian craftsmanship.



## FACTORY AND SHOWROOM

VISIT OUR SHOWROOM  
LOCATED IN THE  
HISTORICAL CITY  
OF VERCELLI



The showroom is located in the heart of the historical Piedmontese city of Vercelli, Italy.

The space has been repurposed from the original (1920 - 1946) Sambonet family silversmithing factory to a showroom. More than 500 m<sup>2</sup> of exposition space. You are very invited to visit us!

Since late 2017, and after a bid to expand its operations to meet growing demand, La Tavola operates two BUILDINGS of 2500 sqm and 5000 sqm respectively for its production and warehousing operations.

la tavola  
italyla tavola  
italy

Patents and Proprietary Designs

## All product designs are registered by La Tavola. Any reproduction or imitation is forbidden by law.

The following products are covered by international patents and copyrights: Dynamic Built-in Modular System®, Libro®, Foldable Front and Back Bar®, Icona®, Icona Secret®, Symphony Action Station®, Symphony Cart®, Symphony Front and Back Bar®, Amphora Cocktail and Buffet Table®, Seagull Front Bar®, Swift F&B Carts and Table®, Goose Heat Lamp®, Magic Chafer®, Multi-purpose Tops®, Cover Oven Dry Chafer®, Dry Warmer for Induction® and Dry Chafer for Induction®.

LA TAVOLA will not hesitate to take legal action against any infringement of patents or registered designs in order to fully protect its intellectual property.

The purchasing of imitation goods may also have legal implications. Design and technical information shown in this document is subject to copyright and may not be used by other parties without prior written approval from LA TAVOLA.

### WARRANTIES

All LA TAVOLA products are guaranteed against any defect of manufacture or material. If, after the manufacturer's inspection, they are found to be defective, they will be repaired or replaced free of charge.

Electrical items and induction-powered items have a 1-year warranty period. After 1-year, La Tavola will ensure limitless availability of spare parts needed as well as consulting and service for repairs.

The warranty does not include damages resulting from misuse, abuse, wear tear or incorrect maintenance.

### CARE AND MAINTENANCE

(Sorted by product category/material)

#### CORE® BUFFET, ACTION STATIONS AND BANQUETING FURNITURE

- » Stainless steel parts: Wash the items with hot water and neutral detergents on a soft cloth (do not use detergent containing chlorine and/or alkaline cleaners). Dry the items thoroughly and store them in a dry place. Never use any type of scraper or steel wool which will scratch the surface of the items. The items must be washed as soon as possible after use to avoid any prolonged contact with food remnants. Do not wash in the dishwasher.
- » PETG elements (transparent covers): Wash the items with water and neutral detergents on a soft cloth (do not use detergent containing chlorine and/or alkaline cleaners). Never use any type of scraper or steel wool which will scratch the surface of the items. Do not wash in the dishwasher.
- » High Pressure Laminates (HPL): wash HPL items with water and neutral detergents on a soft cloth. Never use any type of scraper or steel wool which will scratch the surface of the items. Do not wash in the dishwasher.
- » Organic & Mineral Risers: Ecoresin, like all thermoplastic resin materials, should be cleaned periodically a regular, seasonal cleaning program will dramatically help prevent noticeable weathering and dirt build up. Rinse the sheets with lukewarm water (be careful not to expose edges of organic or fabric interlayers to water) remove dust and dirt from the risers with a soft cloth or sponge and a solution of mild soap and/or liquid detergent in water. Rinse thoroughly with lukewarm water. Never use scrapers or squeegees. Keep edges dry and free of liquids. Do not rub with a dry cloth. Because the materials used are organic in nature (i.e leaves, branches and twigs) it is natural for them to alter slightly in appearance over time. Natural materials are also subject to inherent inconsistency in color, texture and shape. Slight delamination on saw cut edges is also to be expected.

### FLATWARE

» Stainless steel: Wash the items in hot water and neutral washing detergent after each use. Do not use detergents containing chlorine and/or alkali cleaners, then dry thoroughly the items and store them in a dry room. Never use any type of scraper or steel wool which will scratch the surface of the items. Any food remains should be thoroughly cleaned up. The items must be washed as soon as possible after use. When washing in a dishwasher of make sure that at the end of the cycle the items come out perfectly dry otherwise wipe them thoroughly by hand. The above recommendations are particularly meant for the care of the blades, which are made of Aisi 420 stainless steel. This type of stainless steel is the most suitable to ensure a long-lasting cutting edge to the blades, but it is less resistant to the corrosion than the 18-10 (Aisi 304) stainless steel type, which is used to manufacture the forks, the spoons and the handles of the hollow handle knives.

» Silver-plated: The same maintenance instructions of the stainless-steel ware apply. The silver coating can oxidize due to the contact with certain types of food and in very humid climates. This process is not a defect and it is not a sign of damage, but it is a natural characteristic which only alters the color of the surface, initially to yellowish and eventually to brown. Oxidation can be quickly removed with a common silver polishing product, either in form of paste or of liquid solution. In the latter case, it must be taken the precaution of avoiding a prolonged contact of the solution with the stainless-steel blades as they could be affected by corrosion. The items must be removed from the dishwasher as soon as the cycle is completed and wiped dry with a soft cloth, even if they seem dry. The period of time that the items are exposed to hot steam and the hydrochloric acidity created within the dishwasher, therefore items should be removed as soon as possible from the dishwasher after the end of the washing cycle.

» PVD and Titanium Coated: In case of appearance of dark spots (caused by organic substances and/or calcium deposits due to an inadequate washing /drying cycle), remove them by simply wiping off the surfaces with a soft cloth soaked with lemon soap or vinegar. If the lemon soap or the vinegar are not sufficient to remove particularly resistant spots, then (and only in that case) use a soft cloth soaked with a liquid metal polisher. We recommend using "Sidel" by Henkel, but most probably any kind of liquid metal polisher is as good as "Sidel". Avoid polishing the surfaces with abrasive cloth or metal polishing paste. Never use scrubbing sponges. PVD coated flatware does not tarnish, and does not require any special maintenance otherwise. In order to delay as much as possible the incurrance of visible wear and tear, handle with as much care as possible during the washing cycle. Wash and store the knives separately from the forks and the spoon.

### CERTIFICATION

La Tavola is proud to announce that have obtained the ISO 9001:2015 certification.

Our company has always adhered to these principles:

- » Making quality its priority
- » Exceed customer expectations
- » Creating and nurturing a team of excellent people
- » Considering customers as the company's most important asset

In order to achieve these goals and aim for constant, long-term improvement, La Tavola has decided to challenge ourselves and embark on the path towards ISO 9001:2015 certification.

ISO 9001 certification is a worldwide standard that establishes the requirements for a solid Quality Management System. It details the specific processes, procedures and activities that organisations must create, implement, maintain and improve to successfully manage the manufacture of products or delivery of services.

ISO 9001:2015 specifies the requirements for a quality management system when an organisation:

Must demonstrate its ability to consistently provide products and services that satisfy customers and applicable regulatory and legal requirements,

Aims to improve customer satisfaction through effective implementation of the system, including system improvement processes and ensuring compliance with customer and applicable regulatory and legal requirements.



La Tavola has successfully demonstrated its eligibility for certification and is committed to continuous improvement of its products and services to achieve maximum customer satisfaction.

Copyright © LA TAVOLA srl

All rights reserved.

Text and images are property of La Tavola srl and any reproduction (even partial) of the catalogue is forbidden.

In the constant search for technical and functional improvements, La Tavola srl reserves the right to make changes to its products without notice.

Graphic design  
D-Lab - [www.laboratoriodesign.it](http://www.laboratoriodesign.it)

Photography  
Dario Canova

Rendering  
La Tavola Engineering Dpt.

SEP 2025

**la tavola<sup>®</sup>**

LA TAVOLA S.r.l. - Via Pietro Micca, 51 - 13100 Vercelli - ITALY  
phone +39 0161.250062 - [contact@la-tavola.it](mailto:contact@la-tavola.it)  
[www.la-tavola.it](http://www.la-tavola.it)

