

THE GRID

When buffet meets table – a modular link.
Design by sieger design.



buffet | tabletop | bar



When buffet meets table –
a modular link



THE GRID überträgt das modulare Prinzip von VALO auf eine neue Ebene: Das System schafft fließende Übergänge zwischen Buffet und Tisch – für ein durchgängiges Konzept, das Effizienz, Design und Atmosphäre harmonisch verbindet.

THE GRID takes the modular principle of VALO to a new level: the system creates seamless transitions between buffet and table – delivering a coherent concept that harmoniously combines efficiency, design and atmosphere.

THE GRID lleva el principio modular de VALO a un nuevo nivel: el sistema crea transiciones fluidas entre el bufé y la mesa, dando lugar a un concepto continuo que combina de forma armoniosa eficiencia, diseño y ambiente.

THE GRID transpose le principe modulaire de VALO dans une nouvelle dimension : le système crée des transitions fluides entre le buffet et la table et développe un concept cohérent où efficacité, design et atmosphère s'unissent naturellement.



THE GRID verbindet die funktionale Präzision des Buffets mit der Ästhetik der Tischkultur.

Als modulares System aus Porzellan, Glas und Holz eröffnet es neue Möglichkeiten für Präsentation, Service und Inszenierung – von Frühstück bis Fine Dining.

Jedes Element ist Teil eines harmonischen Ganzen: klar in der Form, flexibel in der Anwendung und universell kombinierbar mit dem VALO Buffetsystem.

THE GRID combines the functional precision of the buffet with the aesthetics of table culture.

As a modular system made of porcelain, glass and wood, it opens up new possibilities for presentation, service and staging – from breakfast to fine dining.

Each element is part of a harmonious whole: clear in form, flexible in use and universally compatible with the VALO buffet system.

THE GRID combina la precisión funcional del bufé con la estética de la cultura de la mesa.

Como sistema modular de porcelana, vidrio y madera, ofrece nuevas posibilidades para la presentación, el servicio y la puesta en escena, desde el desayuno hasta la alta cocina.

Cada elemento forma parte de un conjunto armonioso: claro en su forma, flexible en su uso y universalmente combinable con el sistema de buffet VALO.

THE GRID réunit la précision fonctionnelle du buffet et l'esthétique de l'art de la table.

Conçu comme un système modulaire en porcelaine, verre et bois, il ouvre des possibilités inédites de présentation, de service et de mise en scène – du petit-déjeuner au dîner gastronomique.

Chaque élément appartient à un ensemble pensé comme un tout : formes claires, usages flexibles, compatibilité universelle avec le système de buffet VALO.

On the table

Balance in every detail

Ob einzeln inszeniert oder im Zusammenspiel – vom Wasserglas bis zur Etagère: THE GRID fügt sich dank seiner individuellen Kombinationsmöglichkeiten harmonisch in jede Tischsituation ein – vom Frühstücksbuffet bis zum Fine Dining.

Whether standing alone or in combination – from the water glass to the étagère: THE GRID integrates harmoniously into any table setting thanks to its individually combinable elements – from breakfast buffet to fine dining.

Ya sea presentado de forma individual o en conjunto, desde el vaso de agua hasta la bandeja, THE GRID se integra con armonía en cualquier entorno de mesa gracias a sus elementos combinables de forma individual, desde el desayuno tipo buffet hasta la alta cocina.

Que ce soit seul ou en composition – du simple verre à eau à l'étagère complète – THE GRID s'intègre avec aisance à toutes les tables grâce à ses combinaisons libres et cohérentes, du buffet matinal au dîner sophistiqué.









On the buffet

Structure with ease

Ob großzügig arrangiert oder klar gegliedert – THE GRID bringt Ordnung und Leichtigkeit ans Buffet. Die modulare Systemlogik erlaubt variable Höhen, Ebenen sowie Kombinationen und lässt sich flexibel mit dem Buffetsystem VALO sowie verschiedenen Kühlkomponenten kombinieren.

Whether generously arranged or clearly structured – THE GRID brings order and lightness to the buffet. The modular system logic allows for variable heights, levels and combinations, and can be flexibly combined with the VALO buffet system and various cooling components.

Ya sea dispuesto de forma generosa o con una estructura clara, THE GRID aporta orden y ligereza al buffet. La estructura modular permite diferentes alturas, niveles y combinaciones, y se puede utilizar de forma flexible con el sistema de bufé y diversos componentes de refrigeración.

Disposé avec générosité ou structuré de façon concise, THE GRID apporte ordre, légèreté et lisibilité au buffet. Sa logique modulaire permet des hauteurs, niveaux et compositions variables, et se combine facilement avec le système de buffet VALO ainsi qu'avec différents éléments de refroidissement.







Porcelain



Timeless & functional

Porcelain | Plates



Alle Teller sind Teil des modularen THE GRID Systems und frei kombinierbar. Sie lassen sich mit weiteren Elementen aus Porzellan, Glas oder Holz harmonisch verbinden.

All plates are part of the modular THE GRID system and can be freely combined. They connect harmoniously with other elements made of porcelain, glass or wood.

Todos los platos forman parte del sistema modular THE GRID y pueden combinarse libremente. Se integran de forma armoniosa con otros elementos de porcelana, vidrio o madera.

Toutes les assiettes appartiennent au système modulaire THE GRID et se laissent associer librement. Elles dialoguent naturellement avec les autres composants en porcelaine, en verre ou en bois.



20 / 35,5



26 / 35,5

∅: cm / h: cm

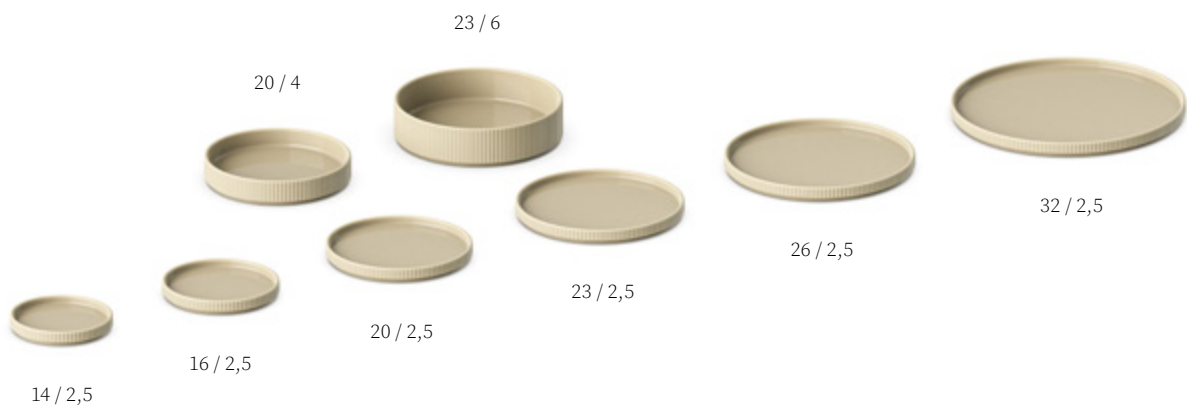

∅: cm / h: cm

Die THE GRID Teller sind in sechs Durchmessern von 14 bis 32 cm erhältlich und folgen einem klaren, einheitlichen Formprinzip. Ihr reduziertes Design mit großzügiger Nutzfläche wirkt zeitgemäß und funktional – ein vielseitiges System, das sich flexibel integrieren lässt.

THE GRID plates are available in six diameters ranging from 14 to 32 cm and follow a clear, consistent design principle. Their reduced design with a generous usable surface appears contemporary and functional – a versatile system that integrates flexibly into any setting.

Los platos THE GRID están disponibles en seis diámetros que van de 14 a 32 cm y siguen un principio de diseño claro y uniforme. Su diseño minimalista, con una amplia superficie útil, tiene un aspecto contemporáneo y funcional: un sistema versátil que se integra de forma flexible en cualquier entorno.

Disponibles en six diamètres, de 14 à 32 cm, les assiettes THE GRID suivent un principe formel clair et homogène. Leur design épuré, conjugué à une surface utile généreuse, crée une esthétique contemporaine et fonctionnelle – un système polyvalent qui s'adapte aux usages.



Porcelain | Bowls



Auch die Porzellanschalen können vielseitig angewendet und für verschiedene Anwendungsfälle praktisch kombiniert werden.

The porcelain bowls can also be used in a variety of ways and combined practically for different applications.

Los cuencos de porcelana también pueden utilizarse de múltiples formas y combinarse de manera práctica para diferentes aplicaciones.

Les bols en porcelaine offrent eux aussi une grande liberté d'utilisation et peuvent être combinés selon les besoins.

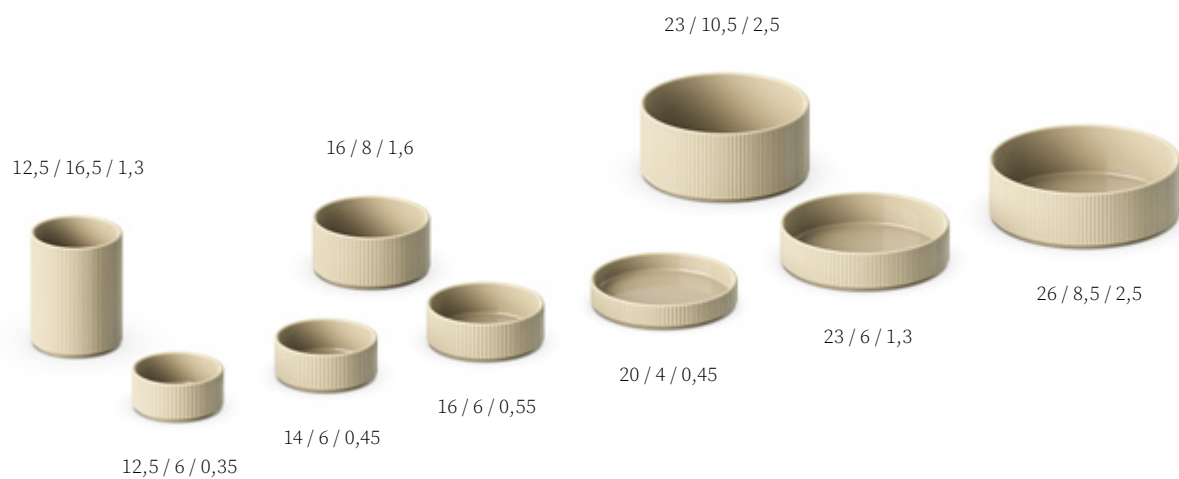

Ø: cm / h: cm / V: ltr.

Die THE GRID Schalen aus Porzellan sind in verschiedenen Größen und Höhen erhältlich und mit vielen Artikeln und Materialien kombinierbar.

THE GRID porcelain bowls are available in various sizes and heights and can be combined with many other items and materials.

Los cuencos de porcelana THE GRID están disponibles en varios tamaños y alturas y pueden combinarse con numerosos artículos y materiales.

Les coupes THE GRID existent en plusieurs tailles et hauteurs, compatibles avec de nombreux articles et matériaux.



Porcelain | Cups, saucers, ramekins

Stackable. Functional. Elegant.



Die THE GRID Tassen und Untertassen sind vielseitig einsetzbar und in verschiedenen Größen für Kaffee, Tee und Espresso erhältlich. Sie lassen sich mit Schälchen und weiteren Porzellanartikeln smart kombinieren und sind sowohl einzeln als auch mit Untertasse stapelbar.

THE GRID cups and saucers are highly versatile and available in different sizes for coffee, tea and espresso. They can be smartly combined with ramekins and other porcelain items and are stackable both individually and with saucers.

Las tazas y platillos THE GRID son muy versátiles y están disponibles en diferentes tamaños para café, té y espresso. Pueden combinarse de forma inteligente con cuencos y otros artículos de porcelana y son apilables tanto individualmente como con su platillo.

Les tasses et soucoupes THE GRID, disponibles dans différentes dimensions pour le café, le thé et l'espresso, peuvent être associées de manière ingénieuse à de petits bols et à d'autres pièces en porcelaine. Elles sont empilables seules ou avec leur soucoupe.



∅: cm / h: cm / V: ltr.

Die drei Tassenformen – Espressotasse, Becher und Universal-tasse – sowie die vier kleinsten Schalen sind mit beiden Untertassen kombinierbar und werden durch einen kleinen Gießer ergänzt.

The three cup shapes – espresso cup, mug and universal cup – as well as the four ramekins can be combined with both saucers and are complemented by a small creamer.

Las tres formas de taza – taza de espresso, vaso y taza universal – así como los cuatro cuencos más pequeños pueden combinarse con ambos platillos y se complementan con una pequeña jarrita.

Les trois formes de tasses – espresso, mug et tasse universelle – ainsi que les quatre plus petites coupes s'accordent aux deux soucoupes et sont complétées par un petit verseur.

Porcelain | Colours



● Sand
25 items

● Mud
25 items

● Sage
14 items

● Marine
6 items

Die Farbwelten Sand und Mud sind für alle Artikel erhältlich, Sage und Marine ergänzen die Palette bei ausgewählten Artikeln.

The colour worlds Sand and Mud are available for all items, while Sage and Marine complement the palette for selected pieces.

Los colores Sand y Mud están disponibles para todos los artículos, mientras que Sage y Marine complementan la paleta de colores para piezas seleccionadas.

Les couleurs Sand et Mud existent pour tous les articles ; Sage et Marine enrichissent la palette pour une sélection de pièces.

Porcelain | Overview

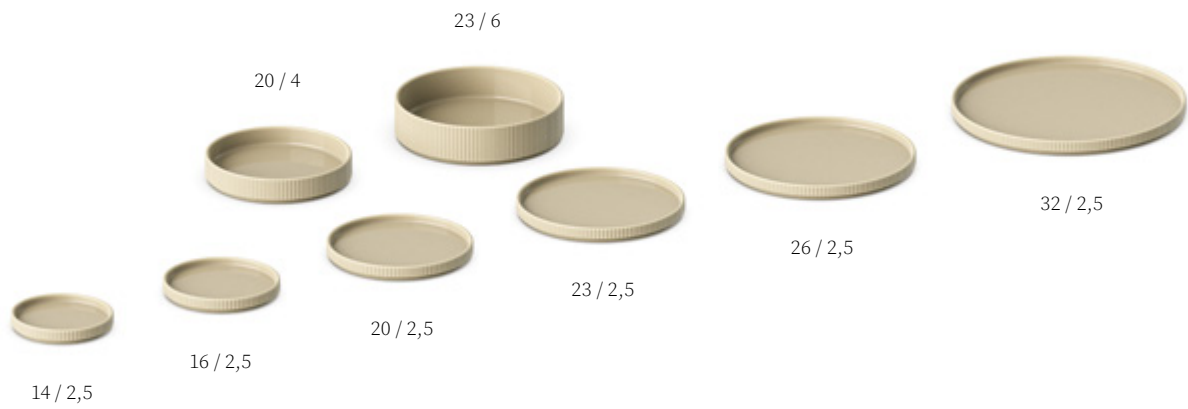

Plates

∅: cm / h: cm

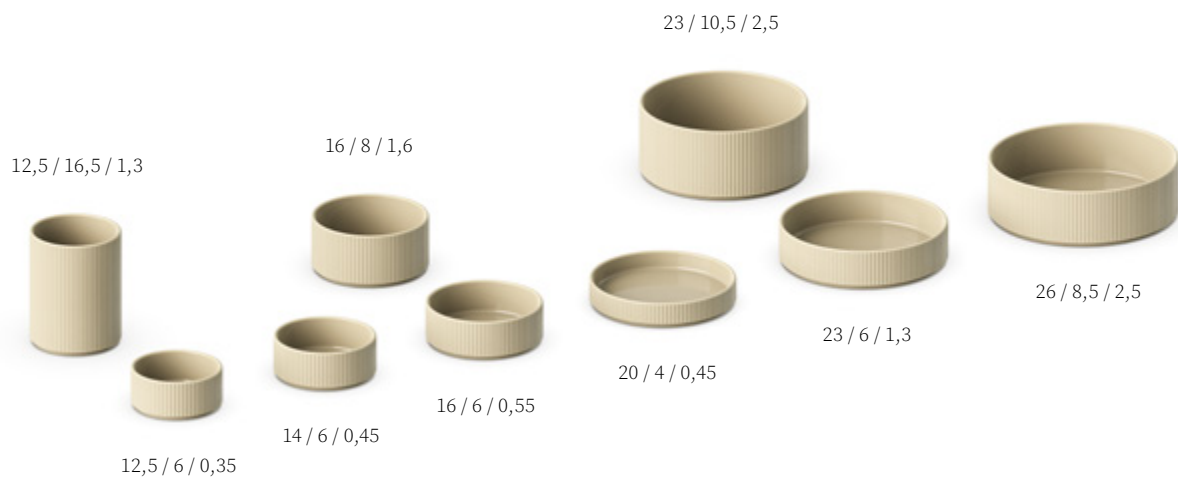

Bowls

∅: cm / h: cm / V: ltr.

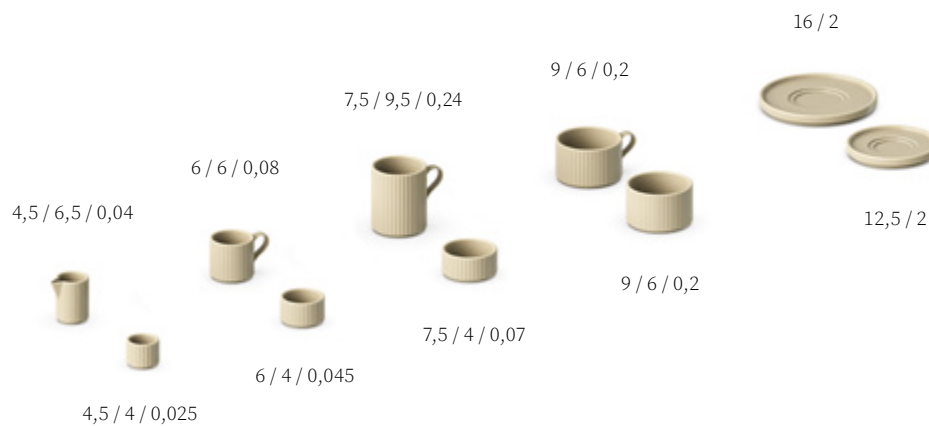

Cups / Ramekins

∅: cm / h: cm / V: ltr.

Glass



Transparent & light

Glass | Drinking glasses, bowls, plates



Auch die THE GRID Glasprodukte sind stapelbar und mit verschiedenen Porzellan- und Holzartikeln vielseitig kombinierbar.

THE GRID glass products are also stackable and can be combined in many ways with different porcelain and wooden items.

Los productos de vidrio THE GRID también son apilables y pueden combinarse de múltiples formas con diferentes artículos de porcelana y madera.

Les articles en verre THE GRID sont eux aussi empilables et se combinent de multiples façons avec les éléments en porcelaine et en bois.



∅: cm / h: cm / V: ltr.

Die sechs THE GRID Glasartikel sind in verschiedenen Größen erhältlich und auf die Maße der Porzellanserie abgestimmt. Die THE GRID Gläser, Schalen und Teller ergänzen das System um eine leichte, transparente Komponente.

The six THE GRID glass items are available in various sizes and are coordinated with the dimensions of the porcelain series. The THE GRID glasses, bowls and plates add a light, transparent component to the system.

Los seis artículos de vidrio THE GRID están disponibles en varios tamaños y se adaptan a las dimensiones de la serie de porcelana. Los vasos THE GRID y los cuencos y platos añaden al sistema un componente ligero y transparente.

Les six pièces en verre THE GRID sont disponibles en plusieurs tailles, ajustées aux dimensions de la série en porcelaine. Verres, coupes et assiettes ajoutent une dimension légère et transparente au système.

Wood | Bowls, plates



Aufgrund der abgestimmten Durchmesser sind die THE GRID Holzartikel in unterschiedlichen Funktionen mit den Porzellan- und Glasartikeln kombinierbar.

Thanks to the coordinated diameters, THE GRID wooden items can be combined in various functions with the porcelain and glass items.

Gracias a los diámetros coordinados, los artículos de madera THE GRID pueden combinarse en diferentes funciones con los artículos de porcelana y vidrio.

Grâce à leurs diamètres harmonisés, les éléments en bois THE GRID s'associent naturellement aux pièces en porcelaine et en verre et peuvent remplir plusieurs fonctions.



∅: cm / h: cm / V: ltr.

Die THE GRID Elemente aus Holz bringen Wärme und Natürlichkeit in das System. Alle Holzartikel sind aus geölter europäischer Eiche aus nachhaltigem Anbau gefertigt und in verschiedenen Größen erhältlich. Durch ihr durchdachtes Design können die Holzsteller zudem auch als Deckel verwendet werden.

THE GRID wooden elements add warmth and natural character to the system. All wooden items are made of oiled European oak from sustainable sources and are available in various sizes. Thanks to their thoughtful design, the wooden plates can also be used as lids.

Los elementos de madera THE GRID aportan calidez y un carácter natural al sistema. Todos los artículos de madera están fabricados en roble europeo aceitado procedente de fuentes sostenibles y están disponibles en varios tamaños. Gracias a su cuidado diseño, los platos de madera también pueden utilizarse como tapas.

Les composants en bois THE GRID apportent chaleur et naturalité à l'ensemble. Tous sont réalisés en chêne européen huilé, issu de cultures durables, et disponibles en différentes tailles. Leur conception ingénieuse permet également d'utiliser les plateaux en bois comme couvercles.

Perfectly chilled



Mit Crushed Ice gefüllt, können alle THE GRID Porzellanschalen zum Kühlen von Speisen genutzt werden.

Filled with crushed ice, all THE GRID porcelain bowls can be used to keep food chilled.

Llenas de hielo picado, todos los cuencos de porcelana THE GRID pueden utilizarse para mantener los alimentos fríos.

Remplis de glace pilée, tous les bols en porcelaine THE GRID peuvent servir au refroidissement des aliments.

Cooling | THE GRID



Kühlkombinationen sind flexibel möglich: Porzellanteller auf Teller oder Teller auf Schale – je nach Einsatz und gewünschter Kühlleistung.

Cooling combinations are flexible: porcelain plate on plate or plate on bowl – depending on the application and desired cooling performance.

Las combinaciones de enfriamiento son flexibles: plato de porcelana sobre plato o plato sobre cuenco, según el uso y el nivel de enfriamiento deseado.

Le refroidissement se module selon l'usage : assiette sur assiette ou assiette sur bol, en fonction de la puissance souhaitée.

Ebenso lassen sich die Glasartikel harmonisch mit kühlenden Porzellanelementen kombinieren.

The glass items can likewise be harmoniously combined with cooling porcelain components.

Del mismo modo, los artículos de vidrio pueden combinarse de forma armoniosa con los elementos de porcelana refrigerantes.

Les articles en verre se combinent également de manière harmonieuse avec les éléments réfrigérants en porcelaine.



Smart cooling options



Zusätzlich zu den integrierten Kühloptionen der THE GRID Produktpalette können weitere smarte Kühlmöglichkeiten in Kombination mit den VALO Lochplatten genutzt werden.

In addition to the integrated cooling options within the THE GRID product range, further smart cooling solutions can be used in combination with the VALO perforated plates.

Además de las opciones de refrigeración integradas en la gama de productos THE GRID, pueden utilizarse otras soluciones de enfriamiento inteligentes en combinación con las placas perforadas VALO.

En complément des solutions de refroidissement intégrées de THE GRID, d'autres options peuvent être mises en œuvre en combinaison avec les plaques perforées VALO.

Cooling | VALO



GN 1/2



GN 1/1



Die VALO Kühlelemente sorgen dank austauschbarer Kühlakkus im isolierten Sockel für langanhaltende Kühlung. Sie bestehen aus einer Schieferplatte und EPP-Liner und basieren auf Gastro-norm-Größen.

The VALO cooling elements provide long-lasting cooling through replaceable packs in an insulated base. They consist of a slate plate and an EPP liner and are based on Gastronorm sizes.

Los elementos refrigerantes VALO proporcionan un enfriamiento duradero gracias a los paquetes reemplazables en una base aislada. Consisten en una placa de pizarra y un revestimiento de EPP y se basan en tamaños Gastronorm.

Les éléments réfrigérants VALO garantissent un froid durable grâce à des accumulateurs échangeables intégrés dans un socle isolé. Ils se composent d'une plaque d'ardoise et d'un revêtement en EPP, basés sur les dimensions Gastronorm.

THE GRID × VALO



Die dimensionsmäßige Abstimmung von THE GRID ermöglicht eine nahtlose Kombination mit dem VALO Sortiment im GN-Format – von Boxen bis zu Etagere.

The dimensional alignment of THE GRID enables seamless combination with the VALO range in GN format – from boxes to tiered stands.

La alineación dimensional de THE GRID permite una combinación fluida con la gama VALO en formato GN, desde cajas hasta bandejas escalonadas.

Les dimensions de THE GRID permettent une compatibilité parfaite avec la gamme VALO au format GN, des boîtes aux étagères.

Additions



Die Etageren gibt es in zwei Größen, sie können flexibel mit ausgewählten Tellern und Schalen kombiniert werden.

The étagères are available in two sizes and can be flexibly combined with selected plates and bowls.

Las bandejas escalonadas están disponibles en dos tamaños y pueden combinarse de forma flexible con platos y cuencos seleccionados.

Les étagères existent en deux tailles et se combinent avec une sélection d'assiettes et de bols.



Auch die Menagen sind im gleichen formalen Duktus gestaltet und lassen sich flexibel bestücken.

The cruet sets are also designed in the same formal language and can be equipped flexibly.

Las aceiteras y vinagreras también siguen el mismo lenguaje formal y pueden equiparse de forma flexible.

Les ménagères reprennent le même langage formel et peuvent être composées de manière flexible.

THE GRID

25 porcelain items, 6 glass items and 6 wood items – one fully combinable system, seamlessly compatible with VALO.

Diameter: cm 4,5 6 7,5 9* 12,5 14* 16

Height: cm



20**

23*

26**

32

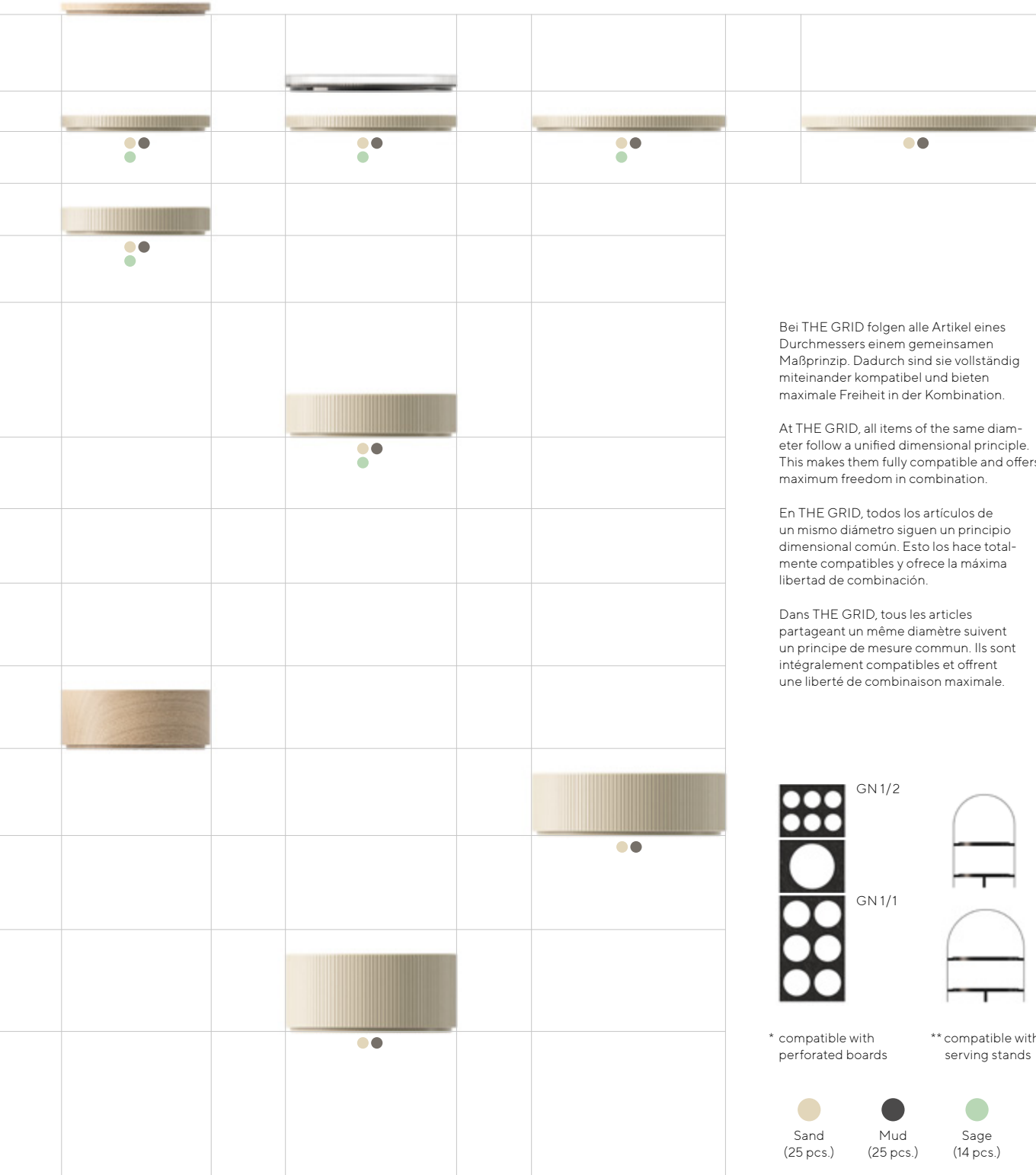

Bei THE GRID folgen alle Artikel eines Durchmessers einem gemeinsamen Maßprinzip. Dadurch sind sie vollständig miteinander kompatibel und bieten maximale Freiheit in der Kombination.

At THE GRID, all items of the same diameter follow a unified dimensional principle. This makes them fully compatible and offers maximum freedom in combination.



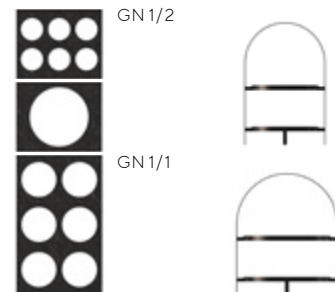

En THE GRID, todos los artículos de un mismo diámetro siguen un principio dimensional común. Esto los hace totalmente compatibles y ofrece la máxima libertad de combinación.

Dans THE GRID, tous les articles partageant un même diamètre suivent un principe de mesure commun. Ils sont intégralement compatibles et offrent une liberté de combinaison maximale.



* compatible with perforated boards

** compatible with serving stands

- 
 Sand
 (25 pcs.)
- 
 Mud
 (25 pcs.)
- 
 Sage
 (14 pcs.)
- 
 Marine
 (6 pcs.)



Schale
bowl
cuenco
bol



	Ø cm	↑ cm	ltr.	VE / unit
19020	4,5	4,0	0,025	12



Schale
bowl
cuenco
bol



	Ø cm	↑ cm	ltr.	VE / unit
19022	6,0	4,0	0,045	12



Schale
bowl
cuenco
bol



	Ø cm	↑ cm	ltr.	VE / unit
19024	7,5	4,0	0,070	6



Schale
bowl
cuenco
bol



	Ø cm	↑ cm	ltr.	VE / unit
19027	9,0	6,0	0,20	6



Schale
bowl
cuenco
bol



	Ø cm	↑ cm	ltr.	VE / unit
19029	12,5	6,0	0,35	6
19030	12,5	16,5	1,30	-



Teller / Schale
plate / bowl
plato / cuenco
assiette / bol



	Ø cm	↑ cm	ltr.	VE / unit
19031	14,0	2,5	-	6
19032	14,0	6,0	0,45	6



Teller / Schale
plate / bowl
plato / cuenco
assiette / bol



	Ø cm	↑ cm	ltr.	VE / unit
19034	16,0	2,5	-	6
19035	16,0	6,0	0,55	6
19036	16,0	8,0	1,60	6



Teller / Schale
plate / bowl
plato / cuenco
assiette / bol



	Ø cm	↑ cm	ltr.	VE / unit
19037	20,0	2,5	-	6
19038	20,0	4,0	0,45	3



Teller / Schale

plate / bowl
plato / cuenco
assiette / bol



	Ø cm	↑ cm	ltr.	VE / unit
19039	23,0	2,5	-	3
19040	23,0	6,0	1,30	3
19041	23,0	10,5	2,50	-



Teller / Schale

plate / bowl
plato / cuenco
assiette / bol



	Ø cm	↑ cm	ltr.	VE / unit
19042	26,0	2,5	-	3
19043	26,0	8,5	2,50	-



Teller

plate
plato
assiette



	Ø cm	↑ cm	VE / unit
19044	32,0	2,5	-



Gießer
 pourer
 vertedor
 pichet



	Ø cm	↑ cm	ltr.	VE / unit
19021	4,5	6,5	0,04	6



Espressotasse
 espresso cup
 taza de espresso
 tasse à espresso



	Ø cm	↑ cm	ltr.	VE / unit
19023	6,0	6,0	0,08	6

Untertasse
 saucer
 platillo
 soucoupe



	Ø cm	↑ cm	VE / unit
19028	12,5	2,0	6



Kaffebecher
 coffee mug
 taza de café
 tasse à café



	Ø cm	↑ cm	ltr.	VE / unit
19025	7,5	9,5	0,24	6

Untertasse
 saucer
 platillo
 soucoupe



	Ø cm	↑ cm	VE / unit
19033	16,0	2,0	6



Cappuccinotasse
 cappuccino cup
 taza de cappuccino
 tasse à cappuccino



	Ø cm	↑ cm	ltr.	VE / unit
19026	9,0	6,0	0,20	6

Untertasse
 saucer
 platillo
 soucoupe



	Ø cm	↑ cm	VE / unit
19033	16,0	2,0	6

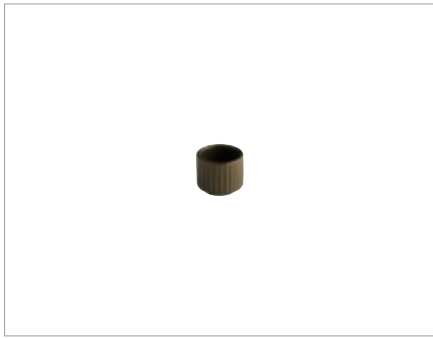

Schale
bowl
cuenco
bol



	Ø cm	↑ cm	ltr.	VE / unit
19060	4,5	4,0	0,025	12



Schale
bowl
cuenco
bol



	Ø cm	↑ cm	ltr.	VE / unit
19062	6,0	4,0	0,045	12



Schale
bowl
cuenco
bol



	Ø cm	↑ cm	ltr.	VE / unit
19064	7,5	4,0	0,070	6



Schale
bowl
cuenco
bol



	Ø cm	↑ cm	ltr.	VE / unit
19067	9,0	6,0	0,20	6



Schale
bowl
cuenco
bol



	Ø cm	↑ cm	ltr.	VE / unit
19069	12,5	6,0	0,35	6
19070	12,5	16,5	1,30	-



Teller / Schale
plate / bowl
plato / cuenco
assiette / bol



	Ø cm	↑ cm	ltr.	VE / unit
19071	14,0	2,5	-	6
19072	14,0	6,0	0,45	6



Teller / Schale
plate / bowl
plato / cuenco
assiette / bol



	Ø cm	↑ cm	ltr.	VE / unit
19074	16,0	2,5	-	6
19075	16,0	6,0	0,55	6
19076	16,0	8,0	1,60	6



Teller / Schale
plate / bowl
plato / cuenco
assiette / bol



	Ø cm	↑ cm	ltr.	VE / unit
19077	20,0	2,5	-	6
19078	20,0	4,0	0,45	3



Teller / Schale

plate / bowl
plato / cuenco
assiette / bol



	Ø cm	↑ cm	ltr.	VE / unit
19079	23,0	2,5	-	3
19080	23,0	6,0	1,30	3
19081	23,0	10,5	2,50	-



Teller / Schale

plate / bowl
plato / cuenco
assiette / bol



	Ø cm	↑ cm	ltr.	VE / unit
19082	26,0	2,5	-	3
19083	26,0	8,5	2,50	-



Teller

plate
plato
assiette



	Ø cm	↑ cm	VE / unit
19084	32,0	2,5	-



Gießer
pourer
vertedor
pichet



	Ø cm	↑ cm	ltr.	VE / unit
19061	4,5	6,5	0,04	6



Espressotasse
espresso cup
taza de espresso
tasse à espresso



	Ø cm	↑ cm	ltr.	VE / unit
19063	6,0	6,0	0,08	6

Untertasse
saucer
platillo
soucoupe



	Ø cm	↑ cm	VE / unit
19068	12,5	2,0	6



Kaffeebecher
coffee mug
taza de café
tasse à café



	Ø cm	↑ cm	ltr.	VE / unit
19065	7,5	9,5	0,24	6

Untertasse
saucer
platillo
soucoupe



	Ø cm	↑ cm	VE / unit
19073	16,0	2,0	6



Cappuccinotasse
cappuccino cup
taza de cappuccino
tasse à cappuccino



	Ø cm	↑ cm	ltr.	VE / unit
19066	9,0	6,0	0,20	6

Untertasse
saucer
platillo
soucoupe



	Ø cm	↑ cm	VE / unit
19073	16,0	2,0	6



Schale
bowl
cuenco
bol



	Ø cm	↑ cm	ltr.	VE / unit
19100	4,5	4,0	0,025	12



Gießßer
pourer
vertedor
pichet



	Ø cm	↑ cm	ltr.	VE / unit
19101	4,5	6,5	0,04	6



Schale
bowl
cuenco
bol



	Ø cm	↑ cm	ltr.	VE / unit
19102	6,0	4,0	0,045	12



Schale
bowl
cuenco
bol



	Ø cm	↑ cm	ltr.	VE / unit
19104	7,5	4,0	0,070	6



Schale
bowl
cuenco
bol



	Ø cm	↑ cm	ltr.	VE / unit
19107	9,0	6,0	0,20	6



Schale
bowl
cuenco
bol



	Ø cm	↑ cm	ltr.	VE / unit
19109	12,5	6,0	0,35	6



Schale
bowl
cuenco
bol



	Ø cm	↑ cm	ltr.	VE / unit
19112	14,0	6,0	0,45	6



Teller / Schale
plate / bowl
plato / cuenco
assiette / bol



	Ø cm	↑ cm	ltr.	VE / unit
19114	16,0	2,5	-	6
19115	16,0	6,0	0,55	6



Teller / Schale
plate / bowl
plato / cuenco
assiette / bol



	Ø cm	↑ cm	ltr.	VE / unit
19117	20,0	2,5	-	6
19118	20,0	4,0	0,45	3



Teller / Schale
plate / bowl
plato / cuenco
assiette / bol



	Ø cm	↑ cm	ltr.	VE / unit
19119	23,0	2,5	-	3
19120	23,0	6,0	1,30	3



Teller
plate bowl
plato cuenco
assiette bol



	Ø cm	↑ cm	VE / unit
19122	26,0	2,5	3



Schale
bowl
cuenco
bol



	Ø cm	↑ cm	ltr.	VE / unit
19140	4,5	4,0	0,025	12



Gießer
pourec
vertedor
pichet



	Ø cm	↑ cm	ltr.	VE / unit
19141	4,5	6,5	0,04	6

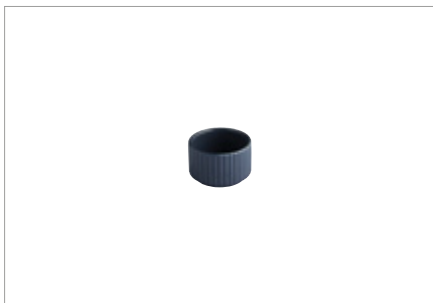

Schale
bowl
cuenco
bol



	Ø cm	↑ cm	ltr.	VE / unit
19142	6,0	4,0	0,045	12



Schale
bowl
cuenco
bol



	Ø cm	↑ cm	ltr.	VE / unit
19144	7,5	4,0	0,070	6



Schale
bowl
cuenco
bol



	Ø cm	↑ cm	ltr.	VE / unit
19149	12,5	6,0	0,35	6



Schale
bowl
cuenco
bol



	Ø cm	↑ cm	ltr.	VE / unit
19155	16,0	6,0	0,55	6



Schale
bowl
cuenco
bol



	Ø cm	↑ cm	ltr.	VE / unit
19000	6,0	3,5	0,045	12



Trinkglas
drinking glass
vaso de agua
verre à boire



	Ø cm	↑ cm	ltr.	VE / unit
19001	7,5	7,5	0,175	6



Schale
bowl
cuenco
bol



	Ø cm	↑ cm	ltr.	VE / unit
19002	12,5	5,5	0,35	12



Schale
bowl
cuenco
bol



	Ø cm	↑ cm	ltr.	VE / unit
19003	14,0	5,5	0,45	6



Teller
plate
plato
assiette



	Ø cm	↑ cm	VE / unit
19004	16,0	2,0	6



Teller
plate
plato
assiette



	Ø cm	↑ cm	VE / unit
19005	23,0	2,0	6



Teller / Schale

plate / bowl
plato / cuenco
assiette / bol



Eichenholz (geölt) / oak wood (oiled) / madera de roble (aceitada) / chêne (huilé)

	Ø cm	↑ cm	ltr.
19010	14,0	1,5	-
19011	14,0	7,0	0,55



Teller / Schale

plate / bowl
plato / cuenco
assiette / bol



Eichenholz (geölt) / oak wood (oiled) / madera de roble (aceitada) / chêne (huilé)

	Ø cm	↑ cm	ltr.
19012	16,0	1,5	-
19013	16,0	7,0	0,72



Teller / Schale

plate / bowl
plato / cuenco
assiette / bol



Eichenholz (geölt) / oak wood (oiled) / madera de roble (aceitada) / chêne (huilé)

	Ø cm	↑ cm	ltr.
19014	20,0	1,5	-
19015	20,0	8,0	1,5

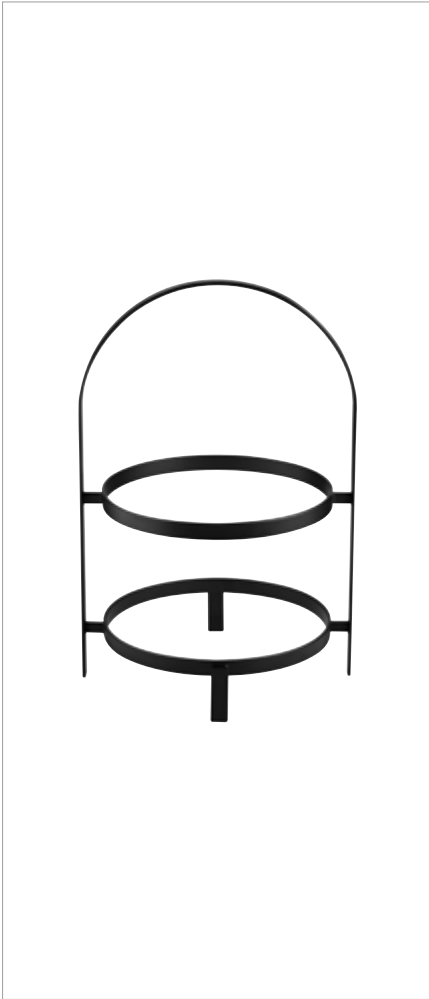

Serviergestell

serving stand
soporte platos
présentoir à assiettes



kompatibel mit allen Artikeln der Serie „THE GRID“ mit Ø 20 cm

compatible with all items in the „THE GRID“ series with a Ø 20 cm

compatible con todos los artículos de la serie „THE GRID“ con un Ø de 20 cm

compatible avec tous les articles de la série „THE GRID“ d'un Ø de 20 cm

	cm	↑ cm
19180	23,5 x 20,5	35,5

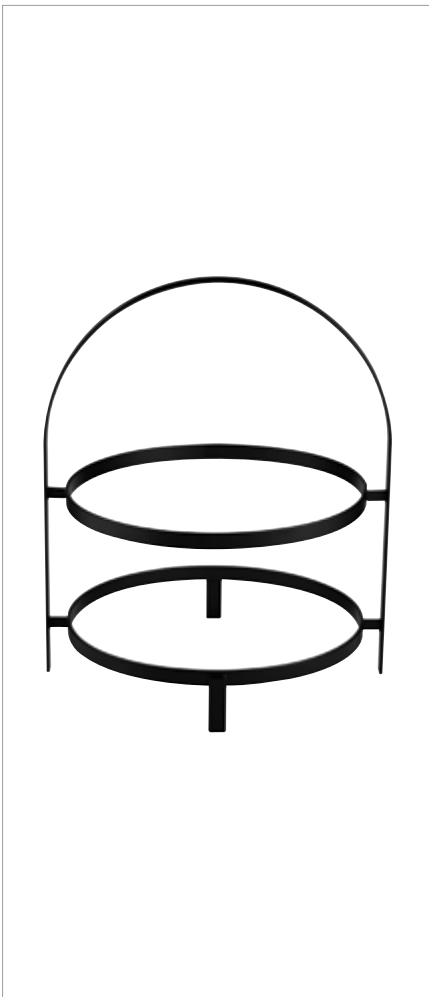

Serviergestell

serving stand
soporte platos
présentoir à assiettes



kompatibel mit allen Artikeln der Serie „THE GRID“ mit Ø 26 cm

compatible with all items in the „THE GRID“ series with a Ø 26 cm

compatible con todos los artículos de la serie „THE GRID“ con un Ø de 26 cm

compatible avec tous les articles de la série „THE GRID“ d'un Ø de 26 cm

	cm	↑ cm
19181	29,5 x 26,5	35,5

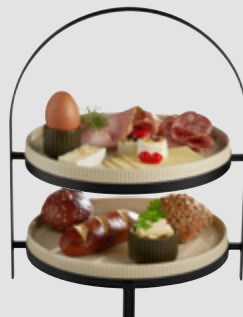



GN 1/1 Naturschieferplatte

GN 1/1 natural slate tray
GN 1/1 bandeja de pizarra natural
GN 1/1 plat ardoise naturelle



kompatibel mit allen Artikeln der Serie „THE GRID“ mit Ø 14 cm

compatible with all items in the „THE GRID“ series with a Ø 14 cm

compatible con todos los artículos de la serie „THE GRID“ con un Ø de 14 cm

compatible avec tous les articles de la série „THE GRID“ d'un Ø de 14 cm

	cm	✦ mm	GN	fits to
19185	53,0 x 32,5	6-9	1/1	VALO GN 1/1



GN 1/2 Naturschieferplatte

GN 1/2 natural slate tray
GN 1/2 bandeja de pizarra natural
GN 1/2 plat ardoise naturelle



kompatibel mit allen Artikeln der Serie „THE GRID“ mit Ø 23 cm

compatible with all items in the „THE GRID“ series with a Ø 23 cm

compatible con todos los artículos de la serie „THE GRID“ con un Ø de 23 cm

compatible avec tous les articles de la série „THE GRID“ d'un Ø de 23 cm

	cm	✦ mm	GN	fits to
19186	32,5 x 26,5	6-9	1/2	VALO GN 1/2, GN 1/1





GN 1/2 Naturschieferplatte

GN 1/2 natural slate tray
GN 1/2 bandeja de pizarra natural
GN 1/2 plat ardoise naturelle



kompatibel mit allen Artikeln der Serie „THE GRID“ mit Ø 9 cm

compatible with all items in the „THE GRID“ series with a Ø 9 cm

compatible con todos los artículos de la serie „THE GRID“ con un Ø de 9 cm

compatible avec tous les articles de la série „THE GRID“ d'un Ø de 9 cm

	cm	✂ mm	GN	fits to
19187	32,5 x 26,5	6 - 9	1/2	VALO GN 1/2, GN 1/1



Kühlakku

cooler
acumulador de frío
accumulateur de froid



	cm	↑ cm	fits to
10791	25 x 19	2,5	14078



GN 1/2 Einsatz „VALO“

GN 1/2 insert
GN 1/2 inserto
GN 1/2 insert



	cm	↑ cm	fits to
14078	30 x 24	4	VALO GN 1/2, GN 1/1 with height: 8,5 cm

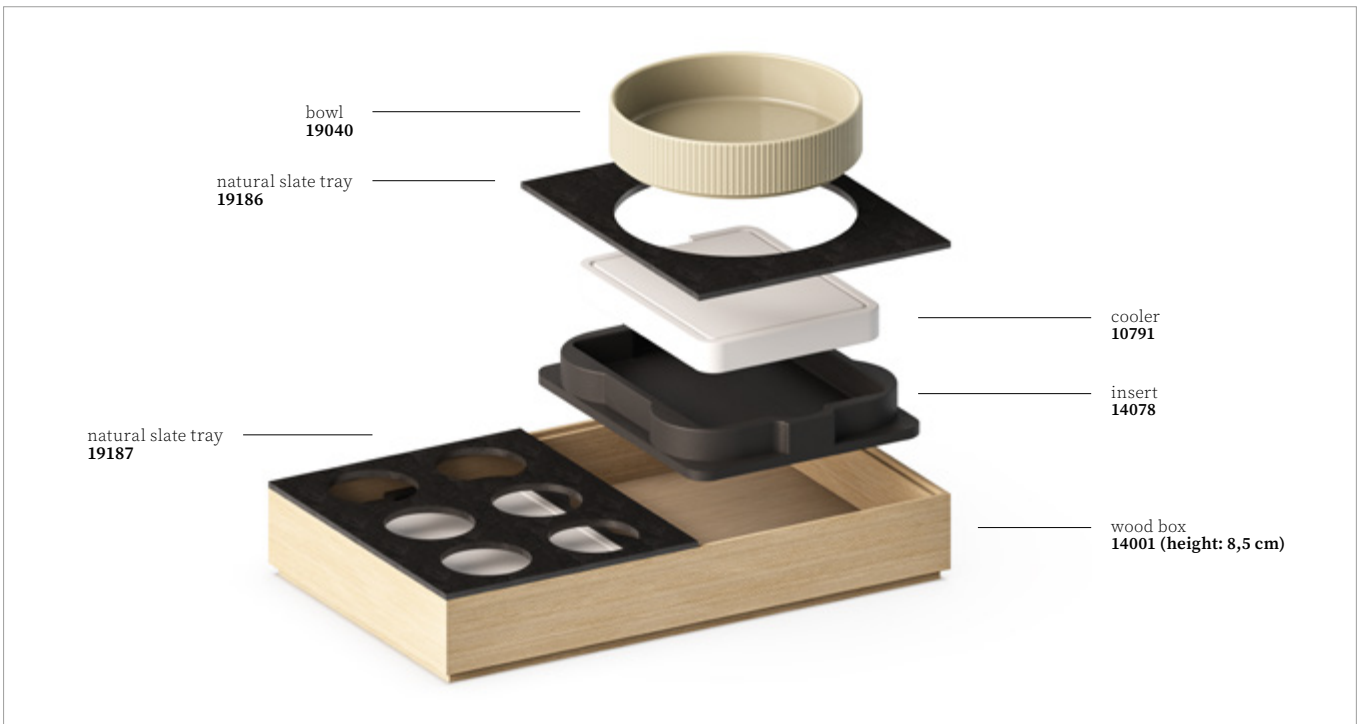

THE GRID x VALO



GN 1/1 Holzbox „VALO“

GN 1/1 woodbox
GN 1/1 caja madera
GN 1/1 base bois

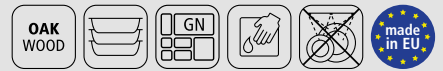

	cm	↑ cm	GN	Farbe / colour
14000	53 x 32,5	4,5	1/1	(oiled)
14001	53 x 32,5	8,5	1/1	(oiled)
14002	53 x 32,5	16,5	1/1	(oiled)

Kompatibel mit den Naturschieferplatten Nr. 19185, 19186 und 19187.
Die Kombination mit dem Kühlsystem (Einsatz Nr. 14078 + Kühlakku Nr. 10791) passt nur in VALO-Boxen mit der Höhe 8,5 cm.

Compatible with natural slate plates no. 19185, 19186 and 19187.
The combination with the cooling system (insert no. 14078 + cooling pack no. 10791) only fits VALO boxes with height 8,5 cm.



GN 1/1 Holzbox „VALO“

GN 1/1 woodbox
GN 1/1 caja madera
GN 1/1 base bois



	cm	↑ cm	GN	Farbe / colour
14100	53 x 32,5	4,5	1/1	(lacquered)
14101	53 x 32,5	8,5	1/1	(lacquered)
14102	53 x 32,5	16,5	1/1	(lacquered)

Kompatibel mit den Naturschieferplatten Nr. 19185, 19186 und 19187.
Die Kombination mit dem Kühlsystem (Einsatz Nr. 14078 + Kühlakku Nr. 10791) passt nur in VALO-Boxen mit der Höhe 8,5 cm.

Compatible with natural slate plates no. 19185, 19186 and 19187.
The combination with the cooling system (insert no. 14078 + cooling pack no. 10791) only fits VALO boxes with height 8,5 cm.





GN 1/2 Holzbox „VALO“

GN 1/2 woodbox
GN 1/2 caja madera
GN 1/2 base bois



	cm	↑ cm	GN	Farbe / colour
14003	32,5 x 26,5	4,5	1/2	(oiled)
14004	32,5 x 26,5	8,5	1/2	(oiled)
14005	32,5 x 26,5	16,5	1/2	(oiled)

Kompatibel mit den Naturschieferplatten Nr. 19186 und 19187.
Die Kombination mit dem Kühlsystem (Einsatz Nr. 14078 + Kühlakku Nr. 10791) passt nur in VALO-Boxen mit der Höhe 8,5 cm.

Compatible with natural slate plates no. 19186 and 19187.
The combination with the cooling system (insert no. 14078 + cooling pack no. 10791) only fits VALO boxes with height 8,5 cm.



GN 1/2 Holzbox „VALO“

GN 1/2 woodbox
GN 1/2 caja madera
GN 1/2 base bois



	cm	↑ cm	GN	Farbe / colour
14103	32,5 x 26,5	4,5	1/2	(lacquered)
14104	32,5 x 26,5	8,5	1/2	(lacquered)
14105	32,5 x 26,5	16,5	1/2	(lacquered)

Kompatibel mit den Naturschieferplatten Nr. 19186 und 19187.
Die Kombination mit dem Kühlsystem (Einsatz Nr. 14078 + Kühlakku Nr. 10791) passt nur in VALO-Boxen mit der Höhe 8,5 cm.

Compatible with natural slate plates no. 19186 and 19187.
The combination with the cooling system (insert no. 14078 + cooling pack no. 10791) only fits VALO boxes with height 8,5 cm.



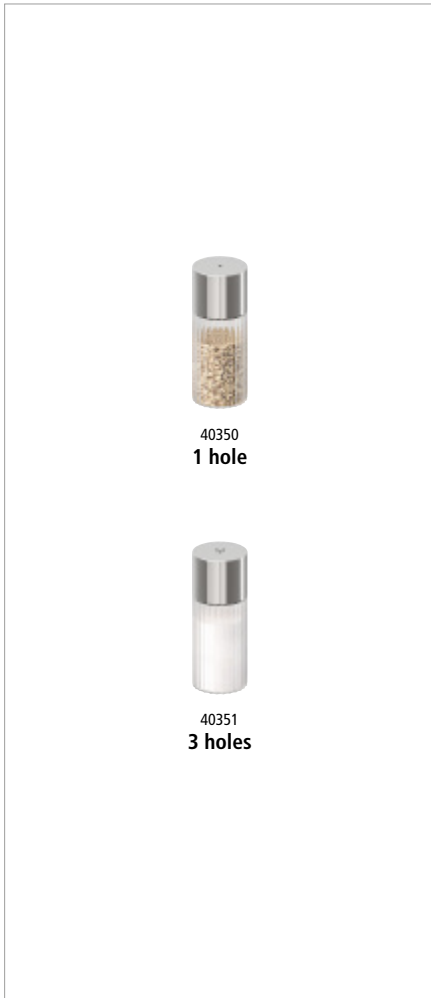

Salz- / Pfefferstreuer

salt / pepper shaker
salero / pimentero
salière / poivrière



	∅ cm	↑ cm	ltr.	
40350	3,5	9	0,04	1 hole – ∅ 2 mm
40351	3,5	9	0,04	3 holes – ∅ 2 mm



Essig- & Öl-Flasche

oil- and vinegar bottle
botella de aceite y vinagre
bouteille d'huile et vinaigre



mit Deckel und integriertem Dosierrohr für ein präzises und kontrolliertes Ausgießen

with lid and integrated measuring tube for precise and controlled pouring
con tapa y tubo dosificador integrado para un vertido preciso y controlado
avec couvercle et tube doseur intégré pour un versement précis et contrôlé

	∅ cm	↑ cm	ltr.
40352	6	15,5	0,2





Zuckerdosierer

sugar dispenser
azucarero
sucrier



mit integriertem Dosierrohr für ein präzises und kontrolliertes Portionieren

with integrated measuring tube, for precise and controlled portioning

con tubo dosificador integrado para un dosificado preciso y controlado

avec tube doseur intégré pour un dosage précis et contrôlé

	Ø cm	↑ cm	ltr.
40353	6	17	0,2



Allzweckgießer

pourer
bote vertedor universal
pot verseur universel
ideal für Kaffeesahne und Milch
ideal for cream and milk
ideal para crema y leche
idéal pour la crème, le lait



	Ø cm	↑ cm	ltr.
40354	6	15,5	0,2





Menage

menage
menage
ménage



Metall matt-schwarz, perfekt zur Präsentation von Essig & Öl sowie Milch & Zucker

metal matte black, perfect for presenting vinegar & oil as well as milk & sugar

metal negro mate, perfecto para presentar vinagre y aceite, así como leche y azúcar

métal noir mat, parfait pour présenter le vinaigre et l'huile ainsi que le lait et le sucre

	cm	↑ cm	fits to
40358	14,5 x 7	30	40352, 40353, 40354



Menage

menage
menage
ménage



Metall matt-schwarz, perfekt zur Präsentation von Essig & Öl, Milch & Zucker sowie Gewürzen

metal matte black, perfect for presenting vinegar & oil, milk & sugar, as well as spices

metal negro mate, perfecto para presentar vinagre y aceite, leche y azúcar, así como especias

métal noir mat, parfait pour présenter le vinaigre et l'huile, le lait et le sucre, ainsi que des épices

	cm	↑ cm	fits to
40359	14,5 x 10,5	30	40350, 40351, 40352, 40353, 40354





MIX
Papier | Fördert
gute Waldnutzung
FSC® C106855



Concept & realisation

sieger design GmbH & Co. KG

Photography

CASA Fotoatelier für Werbung GmbH & Co. KG
ZENITH Werbung & Fotografie GmbH & Co. KG

Printed by

Vorsmann Druck & Verlag GmbH

DE Impressum

Herausgeber: Assheuer + Pott GmbH & Co. KG, Talweg 11, 59846 Sundern, Tel. +49 2933 97350, info@aps-germany.de, www.aps-germany.de
Wir behalten uns das Recht vor, die angegebenen Spezifikationen jederzeit zu ändern. Irrtum, Druckfehler und technische Änderungen vorbehalten.
Artikelbeschreibungen sowie Abbildungen und Fotodarstellungen sind ohne Gewähr. Alle Angebote ohne Dekoration. Alle Preise verstehen sich unverbindlich (UVP) in Euro zuzüglich der gesetzlichen Mehrwertsteuer. © 2026 - Jede Vervielfältigung dieses Katalogs, auch auszugsweise, bedarf der ausdrücklichen Genehmigung der Assheuer + Pott GmbH & Co. KG.

EN Imprint

Editor: Assheuer + Pott GmbH & Co. KG, Talweg 11, 59846 Sundern, Germany, Tel. +49 2933 97350, info@aps-germany.de, www.aps-germany.de
We reserve the right to alter at any time the specifications stated without notice. Errors, printing error and technical changes reserved. Item description as well as images and illustrations are without guaranty. All offers are without commitment (RRP) in Euro and exclude the legal VAT prescribed by law. © 2026 - This catalogue may not be reproduced in whole or in part unless specific prior written authorization of Assheuer + Pott GmbH & Co. KG.



Assheuer + Pott GmbH & Co. KG
Talweg 11, 59846 Sundern / Germany

aps-germany.de

